

# Salvo™

By Sentric

## User Manual



## Section 1- Couplings

Salvo Susie.....	4
Salvo SGL (Glad Hand Lock) .....	6
Salvo Type 1 .....	8
Salvo Club.....	10
Salvo Chock.....	12
Salvo Swap Body Lock.....	14

## Section 2 - Powered Doors

Salvo SCP (Salvo Control Panel).....	17
Salvo Safety Proximity Sensor.....	29
Salvo Safety Limit Switch.....	31
Salvo Door Sensor.....	33
Salvo Transformer.....	35
Salvo Power Supply & Beacon.....	36

## Section 3 - Manual Doors

SMDL-AIS (Manual Door Lock) .....	39
SMDL-AI (Manual Door Lock). .....	42
SADL (Automatic Door Lock) .....	45

## Section 4 - Loading Bay Barriers

Salvo Bollard .....	49
---------------------	----

## Section 5 - Peripherals

Salvo Pedestal.....	52
Salvo Enclosure.....	53
Salvo Presence detection and Alarming System .....	55
Salvo Traffic Lights.....	61

## Section 6 - Safety Critical Information

Safety Critical Information.....	63
----------------------------------	----

# Section 1

# Couplings



The Salvo Susie lock is a key operated mechanical locking device designed to fit on to all UK trailer, emergency brake line connectors. It's purpose is to prevent re-connection of the air brake hose, thereby immobilising the trailer. When fitted, the Salvo Susie can only be removed with the permit key. The Salvo Susie has an ergonomically designed grip. This enables the lock to be fitted and removed efficiently in wet and cold weather. The grip design provides protection to oil and grease making it ideal for harsh environments.

## Operation

The Salvo Susie lock is designed as a part of a safety system to prevent accidental drive aways. The Salvo Susie interlock ensures the vehicle air line is disconnected before the loading bay door can be opened.

- 1 **Disconnect the airline from the trailer Susie air line connector.**
- 2 **Slide the Salvo Susie lock over the exposed air line connector.**
- 3 **Rotate the key anti-clockwise and remove the key.**



To remove the Susie lock from the trailer, insert and rotate the key clock-wise. Pull the lock off the Susie air line connector. When the operation is complete the unit should be returned to either the storage enclosure or to the issuer.

## Precautions



Salvo Susie is heavy. During the course of normal use, it may become dirty, greasy and slippery. If you drop it on your foot, you may sustain serious injury. Handle with care. Wear appropriate personal protective clothing.

## Maintenance

A lubrication point is provided at the opposite end of the key entry aperture. The recommended lubricant is Armna G4789 or equivalent. The recommended lubrication interval is 6-12 months as required. Keeping the Salvo Susie lock clean will ensure long and reliable service.

## Technical Data

Working Temperature	Min -25°C (ice free) Max. +55 °C
Weight	1,0 kg
Material	Stainless steel lock complete with TPE (Thermoplastic Elastomer) sleeve
Standards	(UK) BS AU138b.C type coupling

## Drawing

Dimensions:  
in mm

SALVO SUSIE

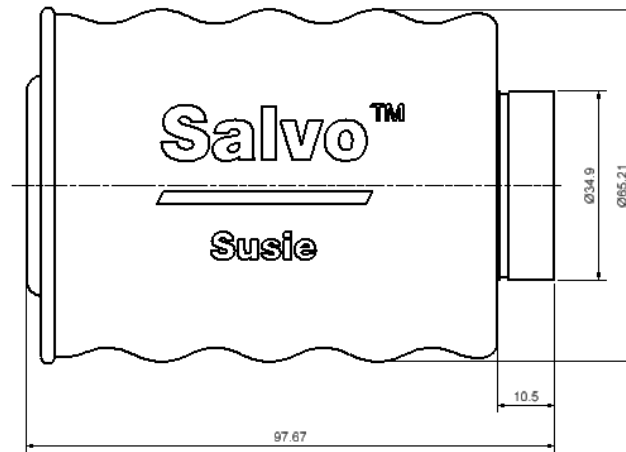

## Order Information

Please advise part number, symbol and dog tag when ordering.  
**(\*\* mandatory information)**

Part Number\*\*

005959

Symbol\*\*

please advise

Dog Tag\*\*

please advise



The Salvo Glad Hand Lock (SGL) is a key operated mechanical locking device designed to fit on to all European and US trailer, emergency brake line connectors. Its purpose is to prevent re-connection of the air brake hose, thereby immobilising the trailer. When fitted, the SGL can only be removed with the permit key.

## Operation

①



Disconnect the airline from the trailer connector, then position SGL location on to the air line connector on the trailer.

②



Push SGL in towards the air line connector.

③

SGL permission buttons



Depress and hold both SGL permission buttons simultaneously and rotate Salvo key 90 degrees counter clockwise.

④



Only when the Salvo SGL is on the connector can the key be rotated anti-clockwise and removed. The SGL is now closed.

Removal of the SGL lock is the reverse of the above procedure.  
When operation is complete, please return to its normal storage location or issuer.

## Precautions



Salvo SGL is heavy. During the course of normal use, it may become dirty, greasy and slippery. If you drop it on your foot, you may sustain serious injury. Handle with care. Wear appropriate personal protective clothing.

## Maintenance

A lubrication point is provided adjacent to the key entry aperture and trigger mechanism. The recommended lubricant is Armna G4789 or equivalent. The recommended lubrication interval is 6-12 months as required. Keeping the Salvo SGL clean will ensure long and reliable service.

### Technical Data

<b>Working Temperature</b>	Min -25°C (ice free) Max. +55 °C
<b>Weight</b>	2,0 kg
<b>Housing Material</b>	Light alloy / Stainless steel
<b>Lock Material</b>	Stainless Steel
<b>Standards</b>	Conforms with; (EU) ISO 1728:2006 Palm Type Coupling (USA) SAE J318 _201305 Glad Hand Connector

### Drawing

Dimensions:  
in mm

SALVO SGL

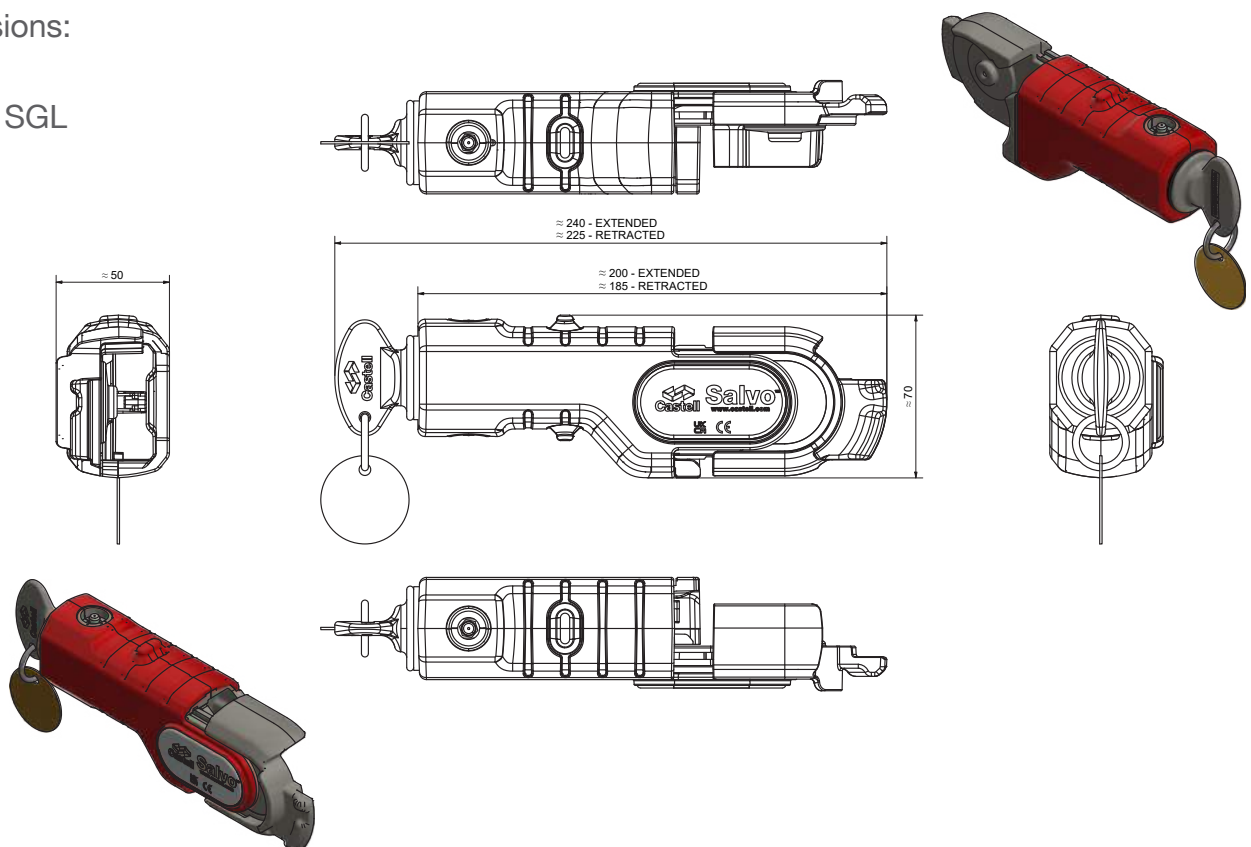

### Order Information

Please advise part number, symbol and dog tag when ordering.  
**(\*\* mandatory information)**

**Part Number\*\***

008040

**Symbol\*\***

please advise

**Dog Tag\*\***

please advise

# Salvo Type 1 User Guide



The Salvo Type 1 lock is a key operated mechanical locking device designed to fit on to all Australian Type 1, emergency brake line connectors. Its purpose is to prevent re-connection of the air brake hose, thereby immobilising the trailer. When fitted, the Salvo Type 1 can only be removed with the permit key.

## Operation

- 1 Disconnect the air line from the Trailer Type1 air line connector.
- 2 Slide the Type1 lock over the exposed air line connector.
- 3 Rotate the key anti-clockwise and remove the key.



To remove the Type1 lock from the trailer, insert and rotate the key clock-wise. Pull the lock off the Type1 air line connector. When the operation is complete the unit should be returned to either the storage enclosure or to the issuer.

## Precautions



Salvo Type 1 is heavy. During the course of normal use, it may become dirty, greasy and slippery. If you drop it on your foot, you may sustain serious injury. Handle with care. Wear appropriate personal protective clothing.

## Maintenance

Apply lubrication to the inner plungers. The recommended lubricant is Armna G4789 or equivalent. The recommended lubrication interval is 6-12 months as required. Keeping the Type 1 lock clean will ensure long and reliable service.



# Salvo Type 1

## User Guide

### Technical Data

Working Temperature	Min -25°C (ice free) Max. +55 °C
Weight	0,5 kg
Housing Material	Stainless steel
Lock Material	Stainless Steel
Standards	Conforms with; AS4945- (R2016)

### Drawing

Dimensions:  
in mm

SALVO TYPE 1

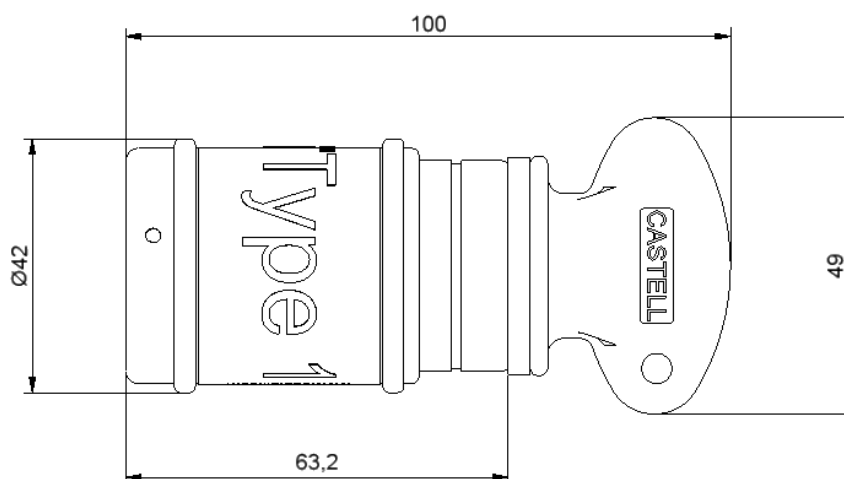

### Order Information

Please advise part number, symbol and dog tag when ordering.  
(\* **mandatory information**)

Part Number\*\*

006505

Symbol\*\*

please advise

Dog Tag\*\*

please advise

# Salvo Club

## User Guide



The Salvo Club helps ensure loading dock safety. The Salvo Club brings added safety to loading dock procedures by locking a vehicle's steering wheel. The Salvo Club can be attached to vehicle steering wheels of varying sizes and will remain locked in place once the Castell key is removed. When loading/unloading procedures are complete, the Castell key may be replaced, and the Salvo Club can be removed allowing the vehicle driver to depart from the loading bay.

### Operation

①

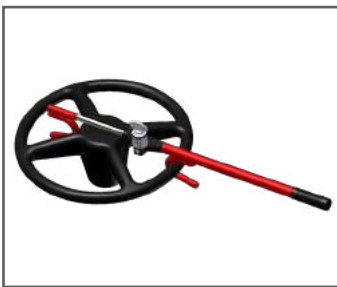

Begin by fully closing the two halves of the Salvo Club. Then place the Salvo Club in position over the steering wheel.

②



Slide the two halves of the Salvo Club apart, engaging the hooks inside the wheel.

③

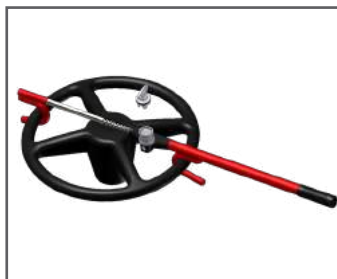

Rotate and remove the key.

④



The Salvo Club is now locked in place restricting rotations of the steering wheel.

### Precautions



Salvo Club will not prevent a vehicle drive-away. It's purpose is to provide a warning that loading/unloading activity may still be ongoing.

It is possible to remove the key when the club is not fitted.

Handle with Care. Beware of pinch points where the two halves slide/telescope together.

### Maintenance

Apply lubrication to the inner plungers. The recommended lubricant is Armna G4789 or equivalent. The recommended lubrication interval is 6-12 months as required. Keeping the Salvo Club lock clean will ensure long and reliable service.

### Technical Data

Working Temperature	NA
Weight	1,5kg
Housing Material	Steel/Cro-moly Steel Construction with heat treated steel hook
Lock Material	Stainless Steel/Brass
Steering Wheel Size	Min. 22cm Internal Diameter; Max. 48cm Internal Diameter

### Drawing

Dimensions:  
in mm

SALVO CLUB

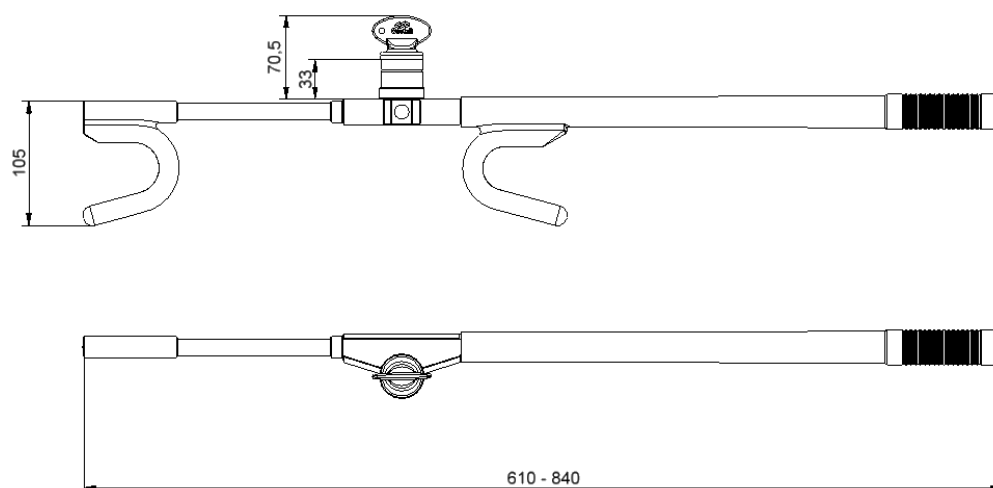

### Order Information

Please advise part number and symbol when ordering.

(\*\* mandatory information)

Part Number\*\*

006476

Symbol\*\*

please advise

# Salvo Chock

## User Guide



Salvo Chock is a device designed to immobilise nonarticulated goods vehicles whilst they are being loaded and unloaded. When used in conjunction with other Salvo products, it can prevent inadvertent or unauthorised drive-aways. It is designed to be deployed on the drivers side front wheel of the vehicle. Salvo Chock introduces discipline into the chocking procedure by interlocking the chock and the loading bay. If the chock is not correctly fitted, the bay door cannot be opened. Like all of the existing products in the Salvo range, Salvo Chock relies on Castell's time-proven trapped-key technology

### Before Use

- 1 When the chock is received, it will be configured for transit. To make the Chock ready for use, the Lock Support Arm must be secured in the operational position.
- 2 The Lock Support Arm must be raised to the vertical position and the Securing Plates (A) fitted to prevent any movement of the arm. The Retention Sleeve (B) should be slid into position around the joint in the spigot.
- 3 To complete the assembly the cover should be fitted with the fixings provided in 6 positions. The Chock is then ready for use.

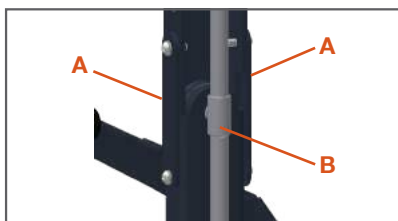
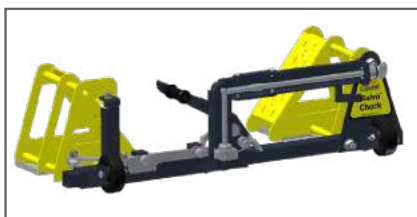

### Operation

The Salvo Chock is designed as a part of a safety system to prevent accidental drive aways. The Salvo Chock ensures the vehicle is locked in position before the loading bay door can be opened

- 1 Salvo Chock assembly is fitted loosely around drivers-side front wheel. Rotate the catch anti-clockwise to the 'up' position, as shown.
- 2 Press the pedal until the two chocks contact the tyre. Continue until lock springs into place.
- 3 When red indicators are aligned, remove the untrapped key. The chock is now secured in place.



### Precautions



Salvo Chock is designed to fit any size or type of rigid vehicle from 3 to 26 tonnes with tyre outside diameter from 27.5 to 42 inches (700 to 1070 mm). To prevent the risk of manual handling injury, only move the chock around using the mobility handle (see photos under Operating Instructions).

Handle with Care. Beware of pinch points where the two halves slide/telescope together.

# Salvo Chock

## User Guide

### Maintenance

Periodic visual checks should be carried out by the site manager / safety officer. Do not lubricate lock barrel with oil or grease, use CK Dry Powder Graphite if necessary.

The recommended grease to lubricate sliding parts is Armna G4789 or equivalent.

### Technical Data

Material	Powder coated carbon steel and aluminium
Weight	26kg
Colour	Safety yellow/graphite grey

### Drawing

Dimensions:  
in mm

SALVO CHOCK

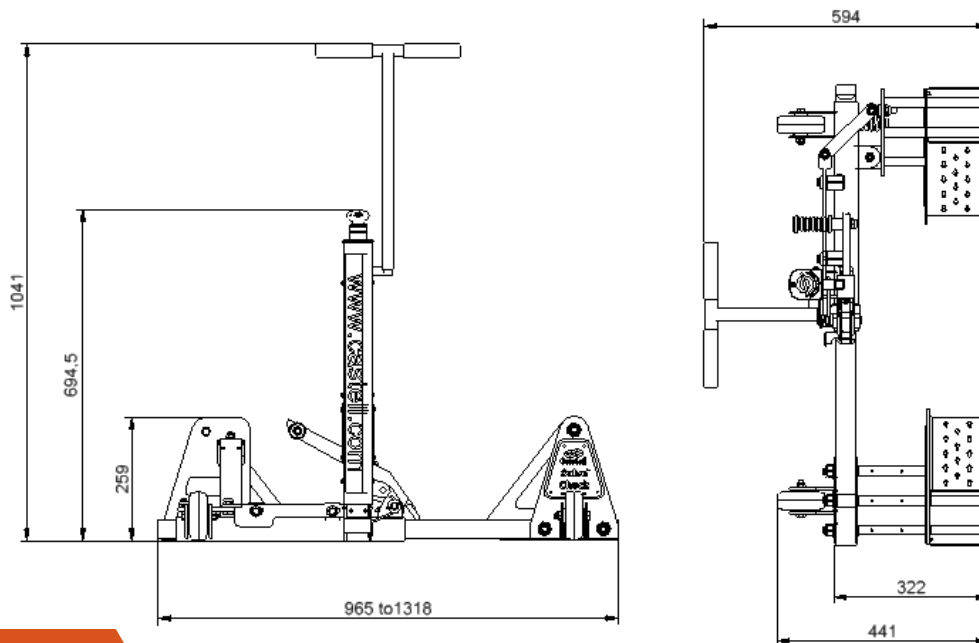

### Order Information

Please advise part number and symbol when ordering.

(\*\* mandatory information)

Part Number\*\*

007058

Symbol\*\*

please advise

# Salvo Swap Body Lock

## User Guide

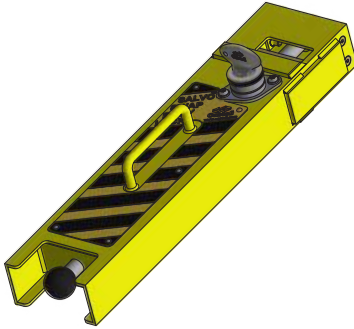

The Salvo Swap Body lock is a key operated mechanical locking device designed to fit into the twist lock aperture on a swap body trailer. When fitted the Salvo Swap Body Lock can only be removed with the permit key. The Salvo Swap Body lock brings added safety to the loading dock procedures by locking into a swap body trailer's twist lock aperture. The Salvo Swap Body Lock remains in place when the Castell key is removed. When the loading/ unloading procedures are complete, the Castell key may be inserted, and the Salvo Swap Body Lock removed, allowing the trailer to connect and the vehicle to depart from the loading bay.

### Operation

The Salvo Swap Body Lock is designed as part of a safety system to prevent accidental drive aways. The Salvo Swap Body Lock ensures obstruction of the twist lock aperture before the loading bay door can be opened.

- 1 Insert Swap Body Lock into twist lock aperture.
- 2 Rotate bar 90 degrees clockwise.
- 3 Rotate the key anti-clockwise and remove the key. Locking the Swap Body Lock in position.

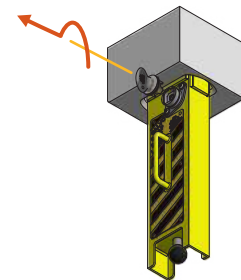
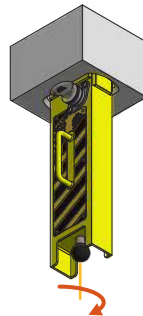
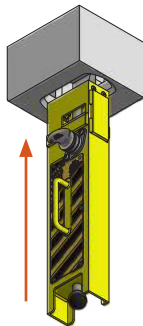

To remove the Salvo Swap Body Lock reverse the above procedure.

### Precautions



Salvo Swap Body Lock is heavy. During the course of normal use, it may become dirty, greasy and slippery. If dropped, the unit could cause serious injury or damage to persons or property. Handle with care. Wear appropriate personal protective clothing.

### Maintenance

Regular checks ensuring moving components move freely including lock portion and key.



Do not grease/oil lock portion.

# Salvo Swap Body Lock

## User Guide

### Technical Data

<b>Working Temperature</b>	Min. -25 0176C (ice free) Max. +55°C
<b>Weight</b>	2.5kg
<b>Material</b>	Stainless steel lock complete with TPE (Thermoplastic Elastomer) sleeve

### Drawing

Dimensions:  
in mm

SALVO SWAP BODY LOCK

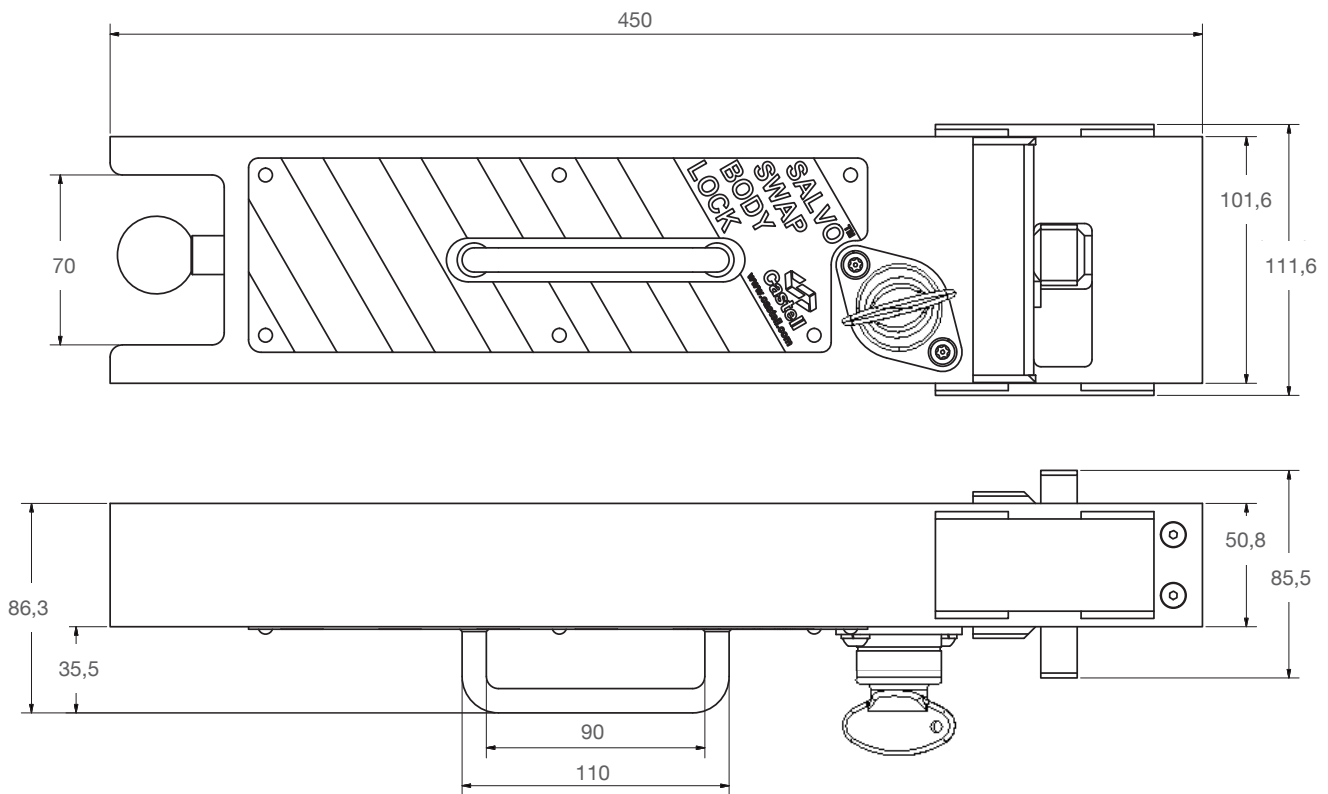

### Order Information

#### Order Information

Part Number



# Section 2

# Powered Doors



# Salvo Control Panel (SCP)

## User Guide



The Salvo Control Panel (SCP) is the main interface between the Salvo couplings and associated bay door controls. The SCP comprises of a wall mounted panel with easy to use Castell interlock key switch to allow operation of the bay. There is also panel indication of status and operation. Installation is via plug in terminals on the internally mounted PCB.

### Operation

The Salvo Control Panel is designed as part of a safety system to prevent accidental drive aways. The Salvo Control Panel ensures that the loading bay door cannot be opened before the vehicle airline is disconnected via the Salvo Susie coupling and the key has been transferred from the coupling to the SCP.

- ① SCP with bay controls isolated, ready to receive key.
- ② Insert key and turn clockwise.
- ③ SCP with bay controls energised, ready to open door and deploy dock leveller.



### Specifications

Temperature (Operating)	Min: -25°C, Max: +55°C
Humidity	30%-70%
Degree of pollution inside the Enclosure	2
Degree of pollution outside the Enclosure	3
Altitude	<2000
Size	232mm(W) x 302mm(H) x 172mm(D) (174mm with Mounting)
Mounting Hole	See page 8-9
Material	Enclosure – ABS/FR (R59M) UL94 5VA Rated Lock Portion – Stainless Steel 304/316
Weight	3.5 kg
Cable Entry Size	M20 knockouts x 2
Switch Approvals	IEC947-1.3 IEC947-5 BS EN60947 VDE 0660
UL Listed	TBA
Ingress Protection	IP65 Enclosure
Switch Rating	Continuous, unattended, remote
Power Supply Required	24VDC
Max Power Consumption	20VA / 20W
Power Frequency	50/60Hz
Relay Specification	Max switching voltage 240VAC 6A, Max switching current 6A

# Salvo Control Panel (SCP)

## User Guide

### Component Inputs

- SPSB (Salvo Power Supply + Beacon)
- SADL (Salvo Automatic Door Lock)
- SBDS (Salvo Bay Door Sensor)

### Component Outputs

- Traffic Light
- Door Control
- Dock Leveller Control
- Amber Beacon

### Precautions



#### Lockout/ Tagout:

Before installing and using your SCP unit, a proper lockout/ tagout procedure should be developed for this unit and related energy sources.

#### Training:

Only those trained in the proper use of this equipment should be allowed to install, use and maintain it.

#### Installation:

Proper installation will ensure safe operation and long life of this product.

Never use this product for anything other than its intended purpose.

It is recommended to route cabling via the cable gland access provided at the base of the unit. Remove knock-outs and fit cable glands provided.

Always make connections to this device in accordance with instructions set forth in this manual and any applicable electrical codes for your area.

A lockable, local disconnect is recommended to properly isolate this unit.

Constantly be aware of vehicle traffic on or near the loading bays.

ESD electrostatic discharge: circuit boards are vulnerable to damage by electrostatic discharge. Before handling any boards ensure you dissipate your body's charge.

#### Operation/ Maintenance:

**WARNING** – Disconnect Electrical Supply Before Opening Unit.



Never operate this unit with the access door open.

Never place any body parts near exposed electrical components.

Avoid poking/ prodding into unit with tools that can conduct electrical current.

Never force the electrical contacts or key solenoid to manually operate this unit.

Failure to follow this instruction could void the manufacturer's warranty

#### Note :

Changes or modifications not expressly approved by Castell Safety could void the user's authority to operate the equipment.

This equipment has been tested and found to comply with the limits for a Class A digital device, pursuant to part 15 of the FCC Rules.

These limits are designed to provide reasonable protection against harmful interference when the equipment is operated in a commercial environment.

This equipment generates, uses, and can radiate radio frequency energy and, if not installed and used in accordance with the instruction manual, may cause harmful interference to radio communications.

Operation of this equipment in a residential area is likely to cause harmful interference in which case the user will be required to correct the interference at his own expense.

This device contains licence-exempt transmitter(s)/receiver(s) that comply with Innovation, Science and Economic Development Canada's license exempt RSS(s). Operation is subject to the following two conditions:

1. This device may not cause interference ;
2. This device must accept any interference, including interference that may cause undesired operation of the device.

# Salvo Control Panel (SCP)

## User Guide

### Preinstallation Check

When preparing to wire multiple devices together for a “system” configuration, it is best to ensure the correct operation of each device independently before starting, to help reduce troubleshooting time later in the event of discrepancy.

Prior to installation, when applying equipment on a new supply circuit, always ensure the correct line voltage exists and is stable. Remember to shut the power off, after this is checked and before performing any wiring of the system.

## Installation 1/4

### Steps for installing the SCP

**Step 1:** Specify location of SADL (inside / outside)

**Step 2:** Mount SCP

**Step 3:** Install multi-core cable

**Step 4(1):** Install Traffic Lights

**Step 4(2):** Install SPSB

**Step 5(1):** Install SADL

**Step 5(2):** Connect Door Close Limit Interface

**Step 6:** Connect Auto Door Control Interface

**Step 7:** Connect Dock Leveller Control Interface.

**Step 8:** Connect power (24VDC)

#### 1 - Specify Location of SCP

Before carrying out installation it is extremely important to determine the location of the SCP. This would depend on the specific site requirement.

The options being:

- Mounted inside the Warehouse where the warehouse staff controls the Salvo coupling.
- Mounted Outside the Warehouse where the shunters/drivers control the Salvo coupling
- If in any doubt contact the site project manager or the Castell Product Manager.

#### 2 - Mount SCP

Depending on site conditions, Ideally the SCP should be mounted 1.5m above floor level. If mounted outside the building, it should be mounted beneath the traffic lights.

If mounted inside the building it should be located adjacent to the dock controls.

#### 3 - Install Multi-core Cable

Consideration should be taken on how the cables are going to run to the various peripherals.

An assessment of site conditions needs to be taken to determine the type of cable used. Armoured cable is suggested for areas of low level of protection against damage by vehicles. CY or SY cable to be used where there is a good level of protection.

The more peripherals and interface connections need, the more cores are required. Consult the wiring diagram to determine the number of cores needed. It is suggested the power cabling is run separately where practicable.

Care should be taken to route and secure all wiring to the Control PCB to avoid interference with the enclosure locking mechanism.

## Installation 2/4

### 4 (1) - Install traffic Lights

Our standard 24VDC traffic lights are to be used (re SETL).  
Connect to Connector 8 Term 7,8,9,10.

9: connect to +ve terminal of red traffic light.  
7: connect to +ve terminal of green traffic light.  
10 & 8: connect to -ve terminal of both red and green traffic light.

### 4 (2) - Install SPSB

**Enclosure:**

205mm(W) 242.5mm(H) 106mm(D)

**Mounting Dimensions:**

187mm(W) 202.5mm(H) - M4

See page 30

**Connections:**

Connector 1, Terminals 1, 2 & 3 (SCP)

1: Connect to +V terminal of PSU

2: Connect to -V terminal of PSU

3: Connect to Earth terminal of PSU

Connector 8, Terminals 5 & 6 (SCP)

5: Connect to + terminal of Beacon connector block

6: Connect to - terminal of Beacon connector block

### 4 (3) - SCP Mounting Instructions

See page 22-23 for mounting installation details (008024).

### Installation 3/4

#### 5(1) - Install SADL

Our standard 24V door locks are to be used (re SADL).  
Connect to terminal 1, 2, 3 & 4 of Connector 2 and terminal 10 of Connector 8.  
Connector 2: terminal 1 connect to terminal 2 of SADL (Door Lock)  
Connector 2: terminal 2 connect to terminal 14 of SADL (Door Lock)  
Connector 2: terminal 3 connect to terminal 4 of SADL (Door Lock)  
Connector 8: terminal 4 connect to terminal 3 of SADL (Door Lock)  
Connector 8: terminal 10 connect to terminal 1 of SADL (Door Lock)



If locating the SCP outside, find a suitable route for the cable through the building wall, and drill cable hole as shown.



Typical SCP installation location outside warehouse.

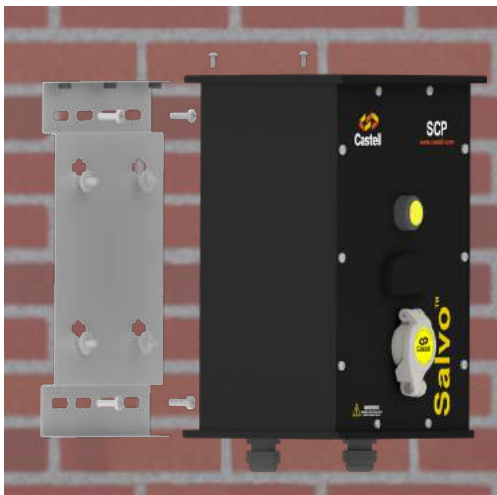

Typical SCP installation location using mounting plate.

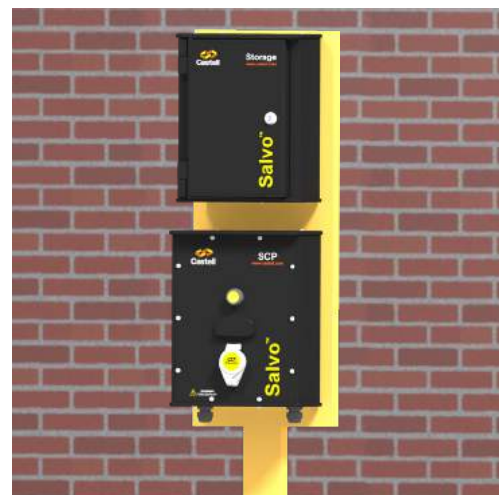

Typical SCP installation location outside warehouse on pedestal.

### Installation 4/4

#### 5(2) - Connect Door Close Limit Interface

In the case of an automatic door there is not a requirement for the SADL however there is a requirement for a signal from the door control panel to indicate the bottom limit.

Connector 2 terminal 1 & 2: connected to bottom limit volt free contacts of the Door control panel.

#### 6 - Auto Door Control Interface

In the case of an automatic door it is necessary to prevent opening of the door when the Castell Key is in the free position.

Connect to Connector 2 terminal 7 & 8:

The 7 & 8 terminals to be connected in series with the Door up push button wiring. OR:

The 7 & 8 terminals to be connected across the door inhibit terminal of the Door control panel.

Please note that the SCP is a failsafe device therefore if there is a failure then the door cannot be opened.

#### 7 - Connect Dock Leveller Control Interface

It may be necessary to prevent activation of the dock leveller when the door is closed.

Connect to terminal 5 & 6 Connector 2.

The 9 & 10 terminals to be connected in series with the Dock leveller raise push button wiring. Please note that if there is a power failure, then the dock leveller cannot be raised.

#### 8 - Power Supply Input



Connect 230/110VAC supply to SPSB (supply to be fused at 3A)

Connect Live to L (AC) terminal of PSU

Connect Neutral to N (AC) terminal of PSU

Connect Earth to Earth terminal of PSU

Means of Isolation should be located adjacent to the device and should be clearly marked and easily accessible.

#### 9 - Check Functions

Check all Functions

#### 10 - Fuse Replacement

The SCP internal fuse is located above the PCB, adjacent to connector TB4, marked "F/Panel Fuse"  
Fuse Rating; 3Amp GSL003 Ø5 x 20mm Time-Lag Glass Tube Fuse (RS668-6007)

# Salvo Control Panel (SCP)

## User Guide

### Function

Function	Condition
Key Free	Door de-activated SADL de-energized Traffic light green Orange beacon OFF Dock leveler de-activated Vehicle restraint de-activated SCP lights (Green if ext, Red if int)
Key Trapped, Door Closed	Door activated but not yet opened SADL energized but not yet opened Traffic light green Orange beacon ON Dock leveler de-activated Vehicle restraint activated SCP lights (Green if ext, Red if int)
Key Trapped, Door Open	Door activated and opened SADL energized and unbolted Traffic light red Orange beacon ON Dock leveler activated Vehicle restraint activated SCP lights (Red if ext, Green if int)

### Wiring

Connect ID	Description	Power Rating	Cable Size
24VDC	24VDC power connections Connector 1 Term 1 & 2	20w	1.5mm <sup>2</sup>

Connect ID	Description	Cable Size
SADL/Door Closed	Solenoid controlled door lock or the door closed contact in the door control panel.	1.5mm <sup>2</sup>

Connect ID	Description	Power Rating	Cable Size
Auto Door	N/O contacts to interlock with the door.	6A	1.5mm <sup>2</sup>
Dock Leveller	N/O contacts to interlock with the Dock leveller.	6A	1.5mm <sup>2</sup>
Traffic Light	Change over contacts to control the traffic lights (24VDC).	6A	1.5mm <sup>2</sup>
Beacon	N/O contacts to control beacon (24VDC).	6A	1.5mm <sup>2</sup>
Aux 1	Change over contacts to control other peripherals.	6A	1.5mm <sup>2</sup>



### SCP Mounting Diagram

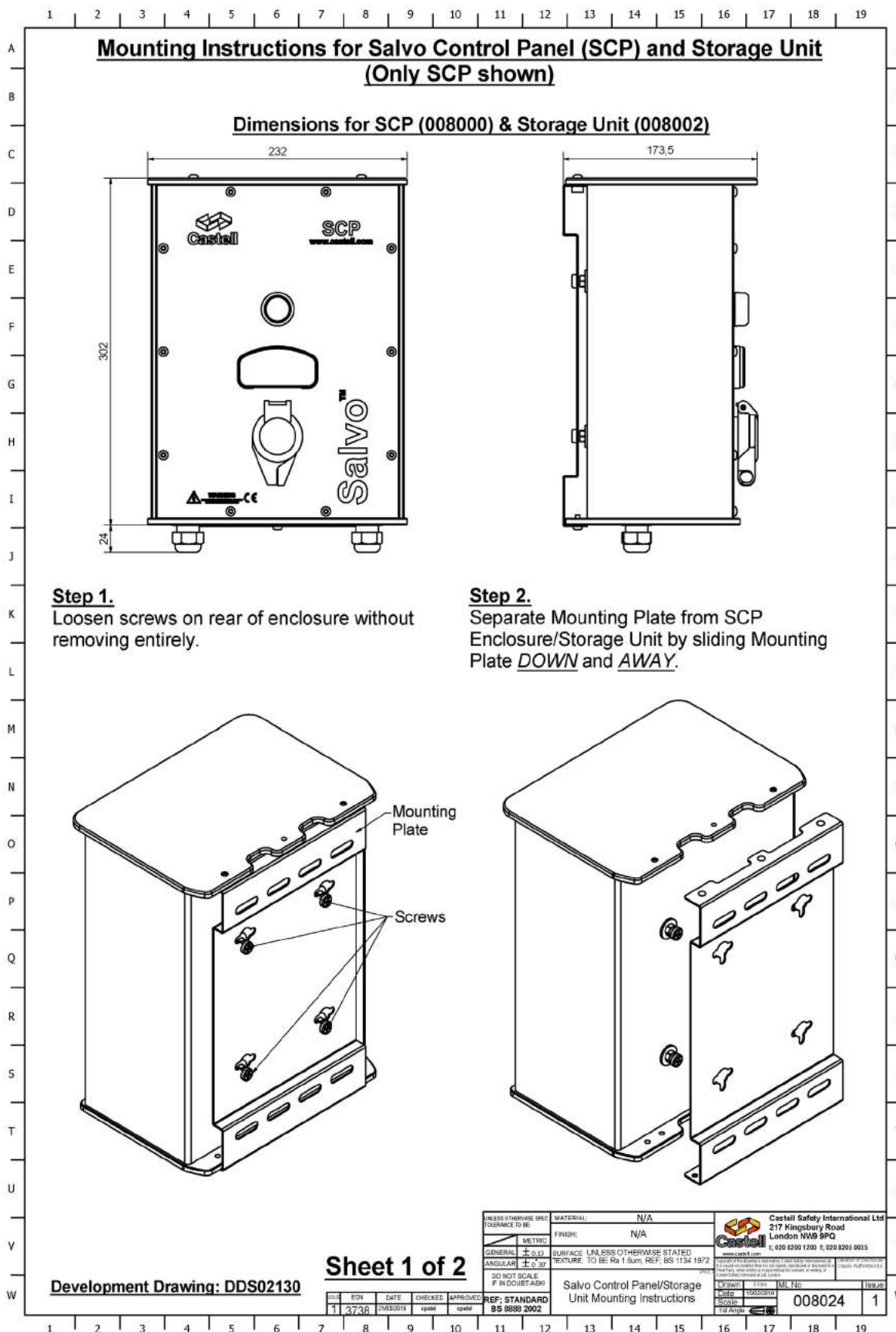

# Salvo Control Panel (SCP)

## User Guide

### SCP Mounting Diagram

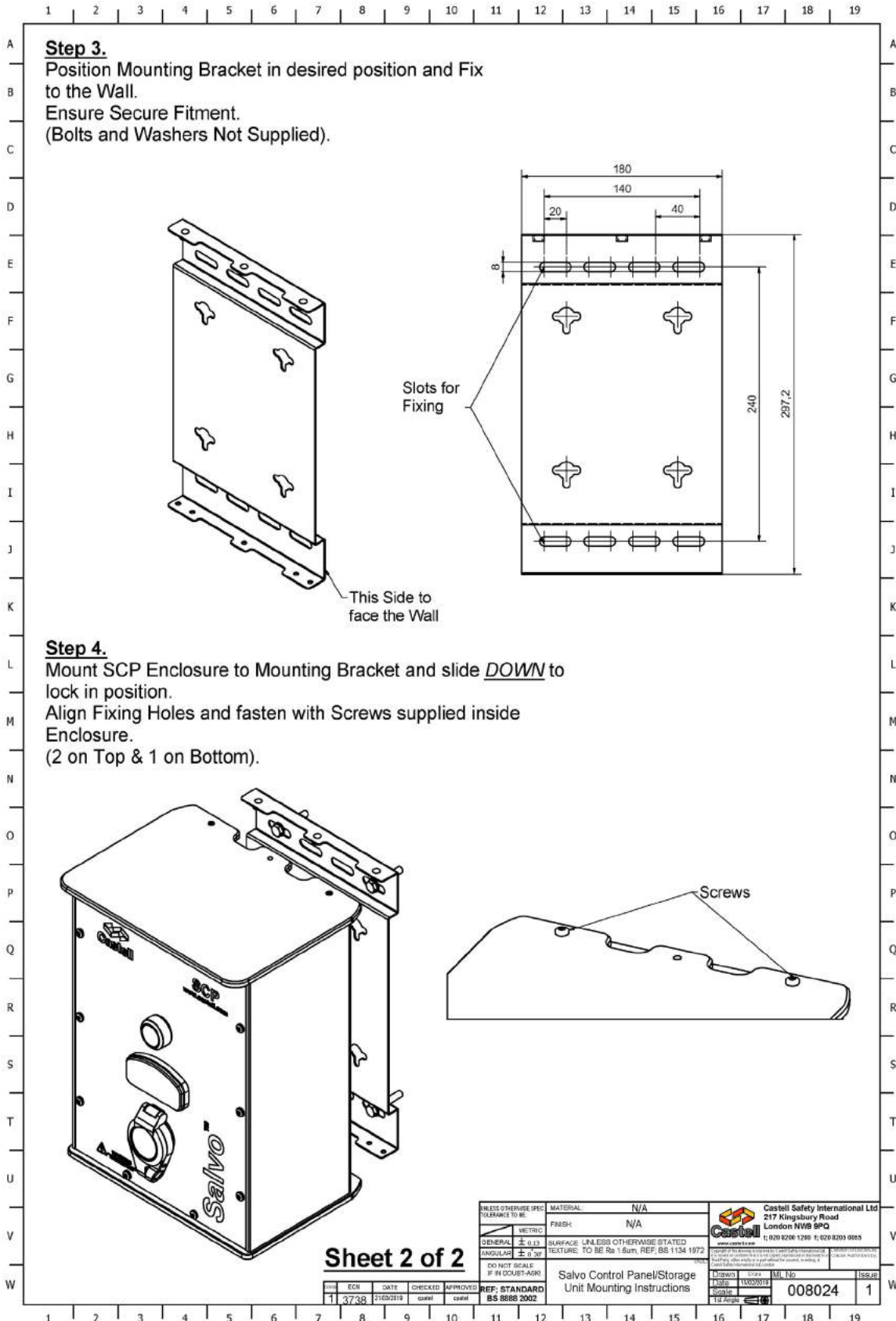

# Salvo Control Panel (SCP)

## User Guide

### Wiring Diagram

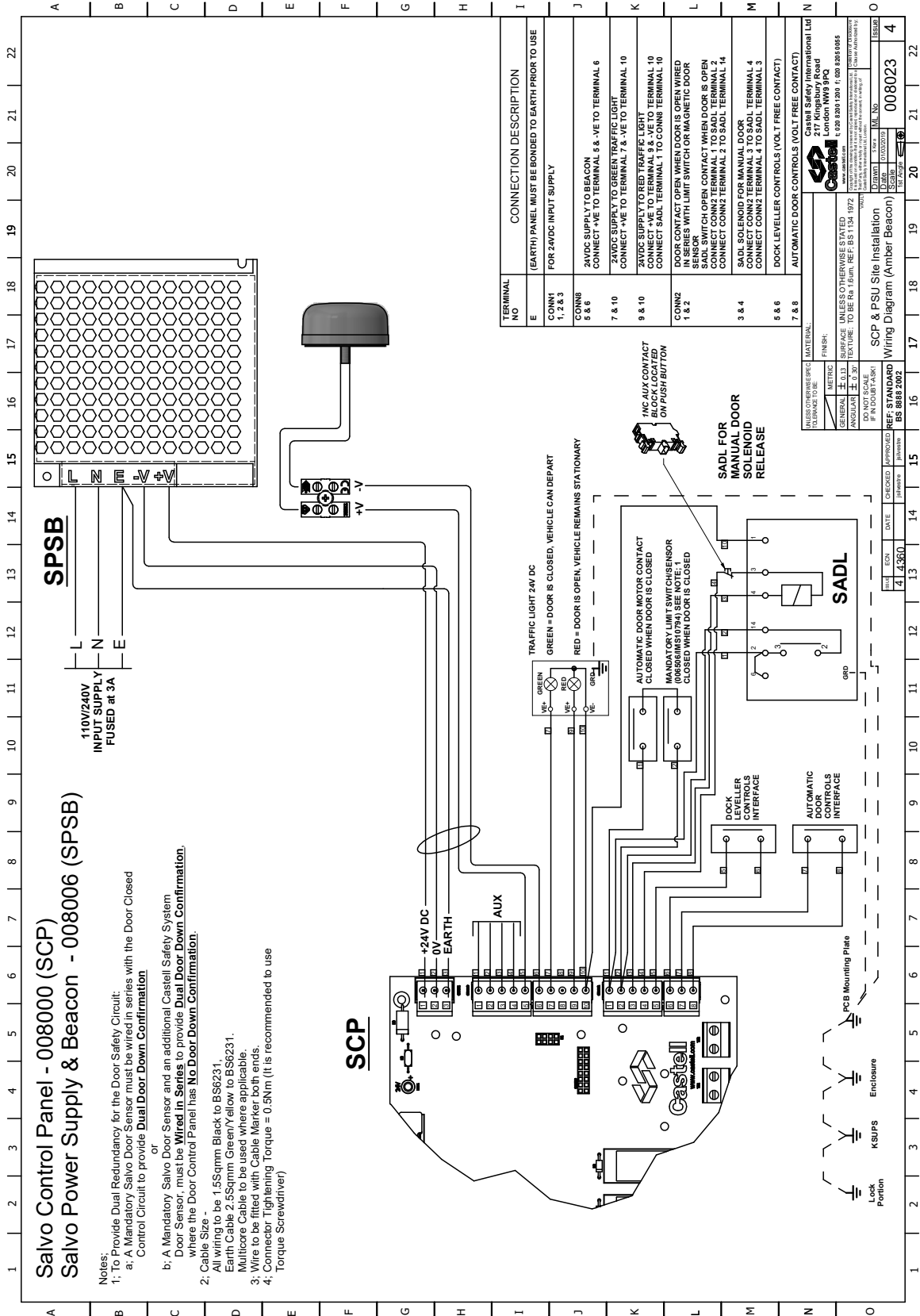

# Salvo Control Panel (SCP)

## User Guide

### Order Information

Please advise part number and symbol when ordering.  
**(\*\* mandatory information)**

**Part Number\*\***

**Symbol\*\***

008000

please advise

# Salvo Safety Proximity Sensor

## User Guide

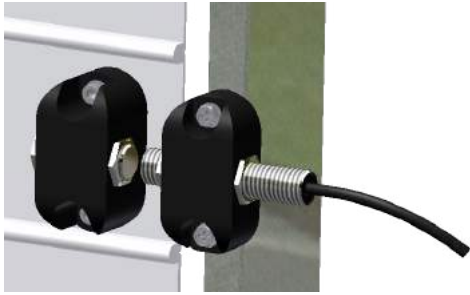

The Salvo Safety Proximity Sensor is designed for use with Roller Shutter Doors, where mechanical Roller Switches cannot be used. It should be mounted in accordance with these instructions, as close to the door frame as possible, to prevent accidental damage.

## Specifications

### Proximity Switch

Contact Form/Style	Normally Open
Switching Capacity (Resistive)	120 W/VA Max
Switching Voltage	1500 VAC Max
Switching Current	3.0 A. Max
Carry Current	5.0 A. Max
Breakdown Voltage	3000 VDC Min
Contact Resistance	80 mOhms Max
Switching Distance	15mm Min
Operating Temperature Range	-20°C / +85°C
Storage Temperature	-25°C / +90°C
Case Material	Brass (Nickel Plated)
Cable	2 x 0.5mm <sup>2</sup> PVC covered Black, insulated Brown / Blue.

### Metal Threaded Magnet

Switching Distance	Normally Open
Operating Temperature	-20°C / +85°C
Storage Temperature	-25°C / +85°C
Case Material	Brass (Nickel Plated)

## Precautions



Installation should be carried out by a competent and qualified person who has read and understood these instructions. Do not use this product as a safety or emergency stop device, or in any other application where failure of the product could result in personal injury. Handle with Care. Beware of Pinch points where the two halves align. Castell Safety recommends that this switch is wired in series with the door down limit switch. Where this is not possible two switches should be used (see Installation Wiring Diagram – IMS08992).

## Maintenance

From time to time, check that all fixing screws remain tight.

# Salvo Safety Proximity Sensor

## User Guide

### Installation

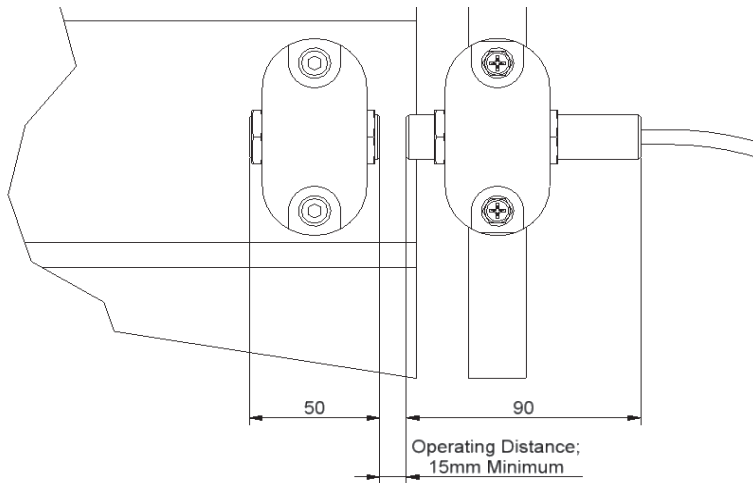

- 1 The magnet should be mounted low enough on the door to ensure it does not reach the point where the door begins to be rolled, when the door is fully opened.
- 2 Align the Switch bracket with the Magnet, mark and drill holes and fix to the frame.
- 3 Ensure the Switch and Magnet align when the door is fully closed.
- 4 Adjust the Switch and Magnet to meet the acceptable operating distance.



Brackets required to fit to Uninsulated Roller Shutter Door

### Order Information

Please advise part number when ordering.  
**(\*\* mandatory information)**

**Part Number\*\***

007050

# Salvo Safety Limit Switch

## User Guide



The Salvo Safety Limit Switch comprises a mechanical roller switch and bracket set. It is mounted so that the roller is actuated by the opening and closing of the loading bay door. It should be mounted in accordance with these instructions, in a raised position to prevent accidental damage.

### Specifications

Product Type	Miniature Safety Limit Switch
Actuator	Side Rotary
Lever Style	Roller Adjustable
Circuitry	1NC 1NO DPST Snap Action
Ampere Rating	10 A (Thermal)
Supply Voltage	240VAC / 250VDC
Housing Material	Plastic
Termination Type	M20
Housing Type	EN 50047
Sealing	IP67 (EN60947-5-1)
Approvals	UL, CSA, CE, CCC, TUV
Mechanical Life	15 Million Cycles
Operating Temperature Range	-30°C to 70°C (-22°F to 158°F)
Agency Approvals and Standards	EN60947-5-1, UL508, CSA C22.2 No14, GB14048.5

### Precautions



Installation should be carried out by a competent and qualified person who has read and understood these instructions. Do not use this product as a safety or emergency stop device, or in any other application where failure of the product could result in personal injury. Handle with Care. Beware of Pinch points where the two halves slide/telescope together. Castell Safety recommends that this switch is wired in series with the door down limit switch (see Installation Wiring Diagram – IMS08992).

### Maintenance

From time to time, check that all fixing screws remain tight.

# Salvo Safety Limit Switch

## User Guide

### Installation

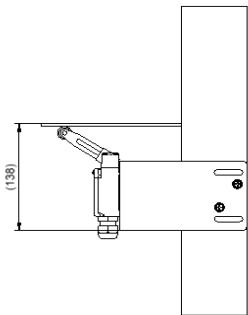

Plan View

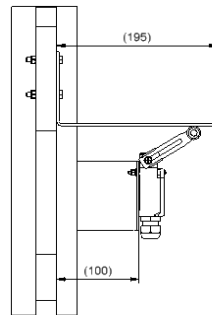
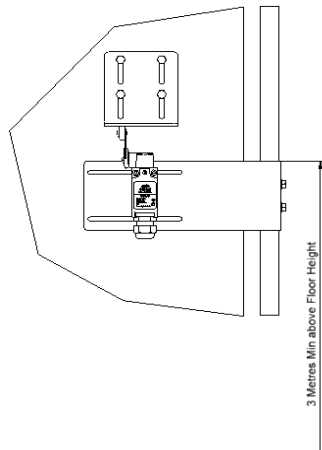

Side Elevation



- 1 The limit switch mounting bracket should be positioned approximately 3m above floor height.
- 2 Align the bracket on the bay door rail and mark the position of the holes.
- 3 Drill the holes, and secure the bracket in place using the fixings provided.
- 4 Position the door bracket to ensure that the switch roller is actuated when the door is fully closed.



Special brackets required to fit to Pre-cast Concrete Installation

### Order Information

Please advise part number when ordering.  
**(\*\* mandatory information)**

**Part Number\*\***

**006506**



# Salvo Door Sensor

## User Guide



The Salvo Door Sensor is designed for use with all doors, when door down confirmation signal is available from door control panel. Where door down confirmation signal is not available from door control panel, a dual redundant system is met by using Salvo Door Sensor plus an additional Salvo sensor. The Salvo Door Sensor should be mounted in accordance with these instructions, and as close to the door frame as possible, to prevent accidental damage.

### Specifications

Product Type	Sensor with GP560 Reed Switch
Contact Form / Style	Normally Open
Switching Capacity	10 VA
Operating Voltage	24V DC
Switching Voltage	100V DC Max 150V AC Max
Switching Current	1A Max
Carry Current	1.5A Max
Breakdown Voltage (typ)	300V DC Min
Contact Resistance (typ)	<300mΩ Max
Switching Distance	5 - 30 mm
Operating Temp °C	-25°C +50°C
Storage Temp °C	-25°C +50°C
Cable	Up to 1 mm <sup>2</sup>
Magnetic Sensitivity	> 0.5mT
Case Material	Cast Aluminium
IP	• IP Rating: IP67 • IK Rating: IK07
Switching Time	0.1 to 0.5 ms
MTTF (reliability)	Up to 1 Million Cycles
RoHS Compliant	Directive (EU) 2015/863
Dimensions	Sensor Contact 3mm x 40mm x 14mm Magnet 2mm x 60mm x 35mm
Standards	• EN50131-1:2006 • EN50131-2-6:2008 Grade 2 • Environmental class III. • PD6662:2017

### Precautions



Installation should be carried out by a competent and qualified person who has read and understood these instructions. Do not use this product as a safety or emergency stop device, or in any other application where failure of the product could result in personal injury. Handle with Care. Beware of Pinch points where the two halves align. Castell Safety recommends that this switch is wired in series with the door down limit switch. Where this is not possible two switches should be used (see Installation Wiring Diagram – IMS08992).

### Maintenance

Sensors should be checked every 6 months to ensure they function correctly and that all fixing screws remain tight. Site should carry out regular safety checks on the Salvo system to ensure key cannot be released from control panel when door is open.

# Salvo Door Sensor

## User Guide

### Installation

- ① Isolate power to the SCP.
- ② Remove 10 screws on front cover of SCP to access the PCB on the inside of the enclosure ensuring screws are retained to close the unit at the end of installation.
- ③ Remove wires connected to CONN 2 terminals 1 and 2 within the PCB.
- ④ Out of the 6 white cables on the Salvo Door Sensor, crimp the cable with Yellow and Black and cut the rest (Ensure the wires are secured to avoid short circuit).
- ⑤ Connect the crimped cables to CONN 2 Terminals 1 and 2 of the PCB. **Please note, these contacts are unidirectional, and it won't matter what side is wired to what terminal.**
- ⑥ Ensure reed side of the sensor is installed in line with the magnet side of the sensor.
- ⑦ Ensure the connection is securely tightened on the flooring (tested for both metal and concrete plinths).
- ⑧ Securely fasten 10 screws using suitable tool torqued @ 1.2Nm.
- ⑨ Provide power to the SCP and test the system for functionality.

**The sensor is unidirectional so any of its contacts can be wired on either terminal.**

### Order Information

Please advise part number when ordering.  
**(\*\* mandatory information)**

**Part Number\*\***

**KIT-RSL-DOOR**

# Salvo Transformer

## User Guide



Salvo Transformer is used to convert power supplies of 415VAC down to 230VAC. It is only required on sites where 230VAC is not available. It is supplied as mounted in a polycarbonate enclosure

### Specifications

Enclosure	Polycarbonate, 180mm (H) x 182mm (W) x 111mm (D)
Cable Entry	2 x M20 Glands
Transformer	63VA Transformer Input (0-230V - 400V) Output (2 x 0-115V)

### Precautions



Installation should be carried out by a competent and qualified person who has read and understood these instructions.

### Order Information

Please advise part number when ordering.

**(\*\* mandatory information)**

**Part Number\*\***

006507

# Salvo Power Supply & Beacon

## User Guide



The Salvo Power Supply converts 110/240V to 24VDC to power the SCP, providing a safer power level at the user interface. The SPSB is mounted to the interior wall of the warehouse, adjacent to the Loading Bay and is combined with an Amber Beacon to provide notification that the Loading Bay has been activated and it is safe to open the bay door and commence loading or unloading.

### Specifications

Power Supply	
<b>Input</b>	
Voltage	100~240VAC (88V ~ 264VAC – Full Range)
Frequency	47 - 63Hz
Current	<2A@115V and 1.2A@230V AC input, full load
Inrush Current	<40A@230VAC input, Cold Start at 25°C ambient
Leakage Current	<2.0mA@240VAC input
<b>Output</b>	
Voltage	24V
Rated Load	0A
Range Load	3.2A
Output Tolerance	+/- 1%
Line Regulation	+/-0.5%
Load Regulation	+/-0.5%
Ripple Noise MAX	120mV
Efficiency (Typ)	85%
Power	76.8W

# Salvo Power Supply & Beacon

## User Guide

### Specifications

#### Enclosure

Material	ABS/FR (R59M) UL94 5VA Rated
Enclosure Dimensions	205mm(W) 220mm(H) 106mm(D)
Mounting Dimensions	187mm(W) 202.5mm(H) – M4
Operating Temperature	-25°C to +115°C
Shock Resistance	20 Joules (IK10)
Ingress Protection	IP65
Weight	1 kg

#### Beacon

Material	Black Polycarbonate
Dimensions	Ø85mm x 38mm(H)
Voltage	11/35VDC
Current	50mA
Operating Temperature	-20°C to +70°C
Ingress Protection	IP65
Cable Entry Size	M20 x 2

### Precautions



**WARNING** – Disconnect Electrical Supply Before Opening Unit



Means of Isolation should be located adjacent to the device and should be clearly marked and easily accessible.



Installation of this equipment, other than for its specified use, may impair the operation and safety integrity of this product.



Installation should be carried out by a competent and qualified person who has read and understood these instructions. Any electrical installation must comply with standard “BS7671 – Requirements for Electrical Installations”, commonly referred to as the IEE Wiring Regulations, or any particular regulations and practices, specified by the local electricity supply company at the time of installation. Installation must be carried out by competent personnel qualified to IEE 17th Edition or any equivalent regulations in force at the time of installation.

### Order Information

Please advise correct part number when ordering.

**(\*\* mandatory information)**

**Part Number\*\***

008006



# Section 3

# Manual Doors

# SMDL-AIS

## User Guide

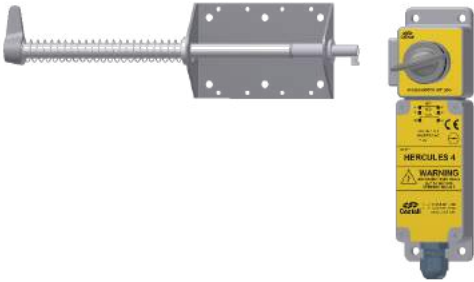

The SMDL-AIS (Salvo Manual Door Lock) is a mechanical interlock used to positively bolt loading bay doors in the closed position. The switch contacts can be used for controlling power to the dock leveller or other ancillary electrical devices e.g. traffic lights. The unit incorporates a locking bolt which passes through the door running rail and into the lock body. Only when the key is inserted and turned, can the locking bolt be disengaged, allowing the door to be opened. The turning of the key closes the switch contacts.

## Operation

When correctly installed, the loading bay door is locked in the down position and the key is removed. With the key removed, the switch contacts are open and the dock leveller is disabled.

To operate, first insert the key and rotate clock-wise. The locking bolt can now be rotated on its axis and released.

The loading bay door can now be opened. With the door open, the key is retained in the lock. The dock leveller can now be operated as normal.

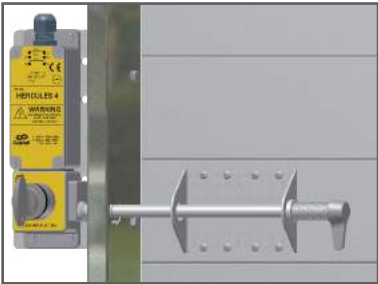
- 

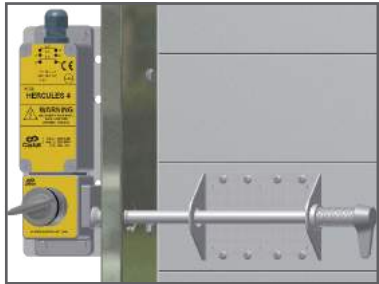
1 Insert the key into the lock.
- 

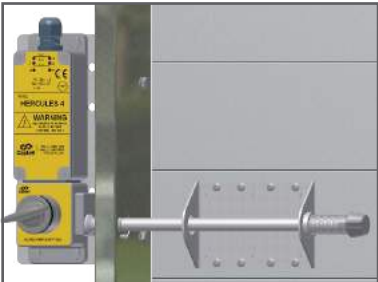
2 Rotate the key clockwise.
- 

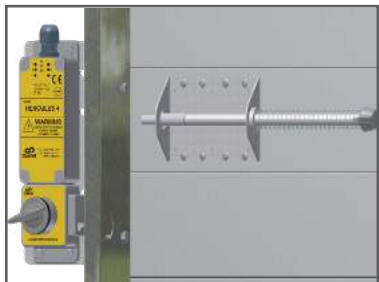
3 Rotate the locking bolt.
- 

4 Release the locking bolt and open the door.

## Precautions



Installation should be carried out by a competent and qualified person who has read and understood these instructions.

### Installation

#### Fixing Instructions

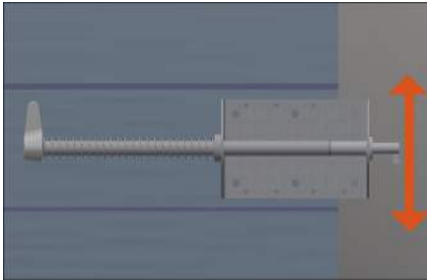

**Step 01:** First ensure the door is fully closed. Determine the position of the locking bolt to ensure that either parts do not clash with existing door fixings. Suggested height between 1.5m and 2m from floor level.

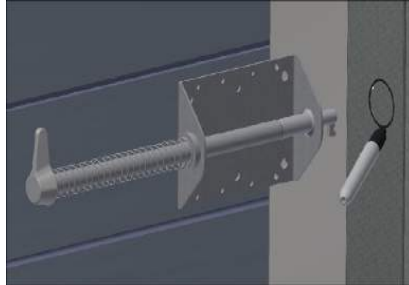

**Step 02:** Mark the position of the bolt clearance hole on the inside of the door running guide. Check that the lock and bolt do not clash with bay controls.



**Step 03:** Drill the clearance hole in the running guide using a 28mm tank cutter.



**Step 04:** Determine the position of the door lock, ensuring that the bolt entry hole aligns with the already secured locking bolt.

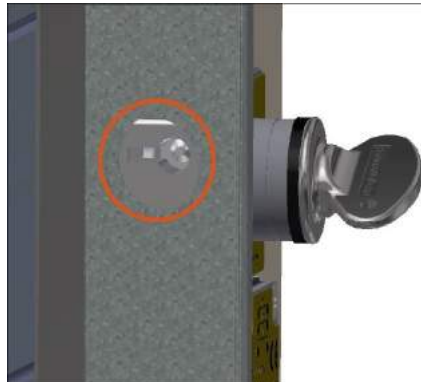

**Step 05:** Use the hole in the door running guide to align the lock.



**Step 06:** Mark and drill the positions of the mounting bracket holes.



**Step 07:** Fix the lock and bracket in place with the screws provided.



**Step 08:** With the door fully closed, engage the bolt into the lock body, through the previously drilled hole in the door running guide. Mark the positions of the fixing holes in the door.

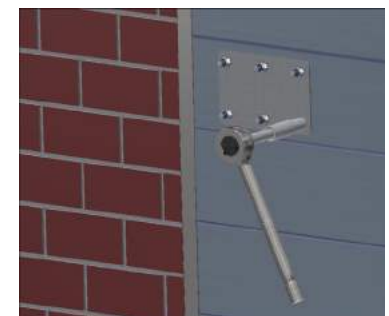

**Step 09:** Drill and pop-rivet two positions. Check that the bolt rotates freely, then drill remaining holes and pop rivet in place.



### Specifications

Weight	1,1 kg
Bolt Material	Stainless steel
Housing Material	Stainless Steel
Lock Material	Stainless Steel
Rating	10A
Ingress Protection	IP65
Termination	PG11
Approvals	VDE, UL, CSA
Mechanical Life	1,000,000 Cycles
Operating Temperature Range	-30°C to 80°C (-22°F to 176°F)

### Maintenance Instructions

Under normal operating conditions very little maintenance is required. If used in dusty conditions, blowing out with compressed air will prevent a build up of sediment in the locks.

The use of powdered graphite is recommended if necessary. Under no circumstances, however, should the locks be oiled or greased as this causes the locks to clog and malfunction.

All locking systems should be checked regularly for correct operation, security of fixings and condition of keys etc.

The function of all keys that should be trapped must be checked under operating conditions, as should the ease of removal of released keys.

In the event of malfunction, evident wear or damage, parts should be replaced or returned to Castell for repair if appropriate.

Users of interlock systems have a duty under Section 2 of the Health and Safety at Work etc Act 1974 to ensure that the systems are correctly installed and maintained in a satisfactory condition.

### Order Information

Please advise correct part number and symbol when ordering.

**(\*\* mandatory information)**

Part Number**	Description	Symbol**
006508	Hand 1, With Bolt	please advise
007044	Hand 1, With Chain Kit	please advise
006509	Hand 2, With Bolt	please advise
007045	Hand 2, With Chain Kit	please advise

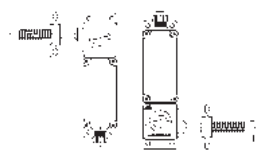

Hand 1 Hand 2

# SMDL-AI

## User Guide

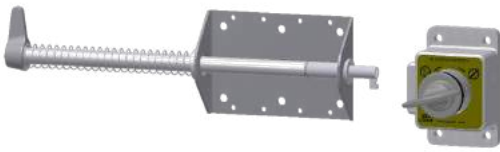

The SMDL-AI (Salvo Manual Door Lock) is a mechanical interlock used to positively bolt loading bay doors in the closed position. The unit incorporates a locking bolt which passes through the door running rail and into the lock body. Only when the key is inserted and turned, can the locking bolt be disengaged, allowing the door to be opened.

### Operation

When correctly installed, the loading bay door is locked in the down position and the key is removed.

To operate, first insert the key and rotate clock-wise. The locking bolt can now be rotated on its axis and released.

The loading bay door can now be opened. With the door open, the key is retained in the lock. The dock leveller can now be operated as normal.

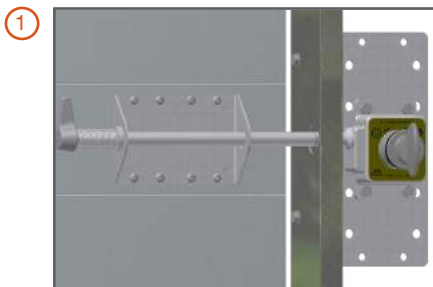

① Insert the key into the lock.

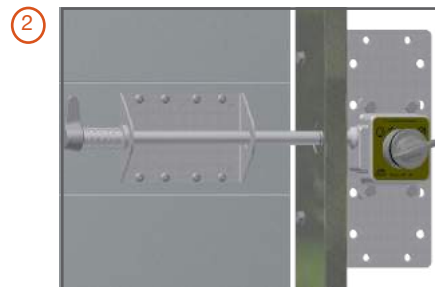

② Rotate the key clockwise.

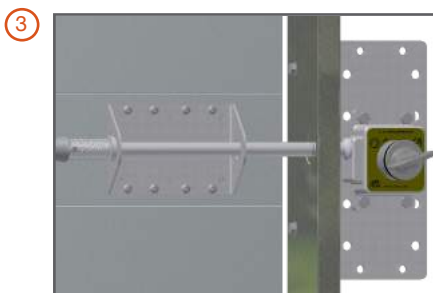

③ Rotate the locking bolt.

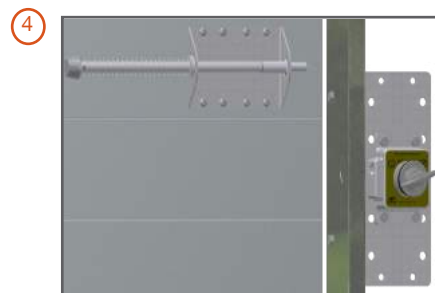

④ Release the locking bolt and open the door.

### Precautions



Installation should be carried out by a competent and qualified person who has read and understood these instructions.

### Installation

#### Fixing Instructions

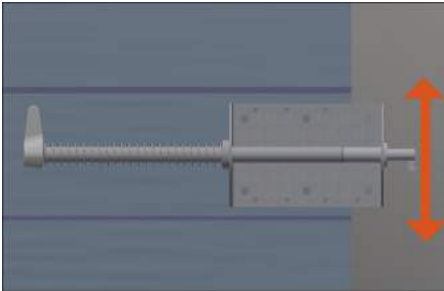

**Step 01:** First ensure the door is fully closed. Determine the position of the locking bolt to ensure that either parts do not clash with existing door fixings. Suggested height between 1.5m and 2m from floor level.

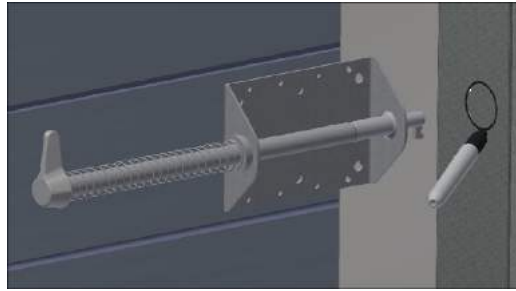

**Step 02:** Mark the position of the bolt clearance hole on the inside of the door running guide. Check that the lock and bolt do not clash with bay controls.



**Step 03:** Drill the clearance hole in the running guide using a 28mm tank cutter.



**Step 04:** Determine the position of the door, ensuring that the bolt entry hole aligns with the already secured locking bolt.



**Step 05:** Use the hole in the door running guide to align the lock.

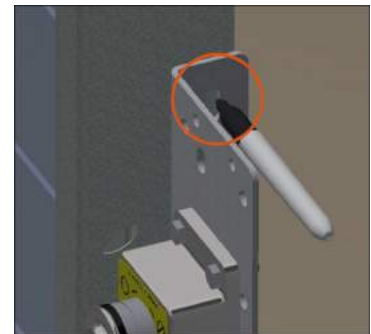

**Step 06:** Mark and drill the positions of the mounting bracket holes.



**Step 07:** Fix the lock and bracket in place with the screws provided.

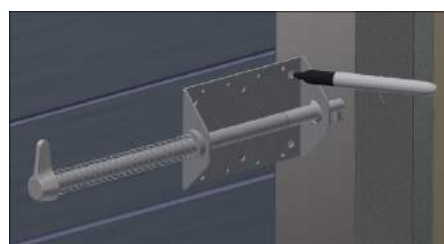

**Step 08:** With the door fully closed, engage the bolt into the door lock., through the previously drilled hole in the door running guide. Mark the positions of the fixing holes in the door.



**Step 09:** Drill holes and fix in place using bolts, washers and nuts, supplied. Trim excess bolt length if necessary.

### Specifications

Weight	1,1 kg
Bolt Material	Stainless steel
Housing Material	Stainless Steel
Lock Material	Stainless Steel
Mechanical Life	1,000,000 Cycles
Operating Temperature Range	-40°C to 140°C (-40°F to 284°F)

### Maintenance Instructions

Under normal operating conditions very little maintenance is required. If used in dusty conditions, blowing out with compressed air will prevent a build up of sediment in the locks.

The use of powdered graphite is recommended if necessary. Under no circumstances, however, should the locks be oiled or greased as this causes the locks to clog and malfunction. All locking systems should be checked regularly for correct operation, security of fixings and condition of keys etc.

The function of all keys that should be trapped must be checked under operating conditions, as should the ease of removal of released keys. In the event of malfunction, evident wear or damage, parts should be replaced or returned to Castell for repair if appropriate.

Users of interlock systems have a duty under Section 2 of the Health and Safety at Work etc Act 1974 to ensure that the systems are correctly installed and maintained in a satisfactory condition.

### Order Information

Please advise correct part number and symbol when ordering.  
**(\*\* mandatory information)**

Part Number**	Description	Symbol**
006510	Hand 1, With Bolt	please advise
007041	Hand 1, With Chain Kit	please advise
006511	Hand 2, With Bolt	please advise
007043	Hand 2, With Chain Kit	please advise

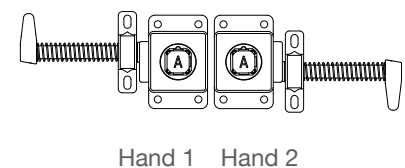

# SADL

## User Guide

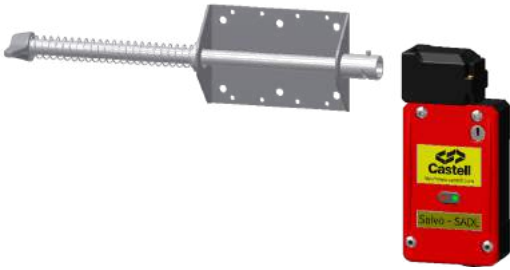

The SADL is a keyless solenoid controlled Lock that locks and unlocks dependent upon the signal received from the Salvo Control Panel (SCP). The unit incorporates a locking bolt which passes through the door running rail and into the lock body. Only when the signal is received from the SCP, can the locking bolt be disengaged, allowing the door to be opened.

### Operation

The SADL is a keyless solenoid controlled lock that locks and unlocks dependant on the signal received from the SCP unit. When the SGL is fitted to a truck the key is released and is then taken to be inserted into the SCP. Once inserted and turned it will send a signal to the SADL illuminating the green LED and electromechanically allowing the removal of the bolt, this therefore allows the opening of the dock door or a chain barrier. When the bolt is removed, a yellow light illuminates indicating that access has been granted and will also send a signal back to the SCP locking the key in its panel, this prevents the removal of the permit key while loading is granted.

### Precautions



Installation should be carried out by a qualified electrician. Please retain this document.

### Wiring Instructions

Electrical Connection - Refer to Salvo Control Panel Wiring Diagram.

### Installation

#### Fixing Instructions

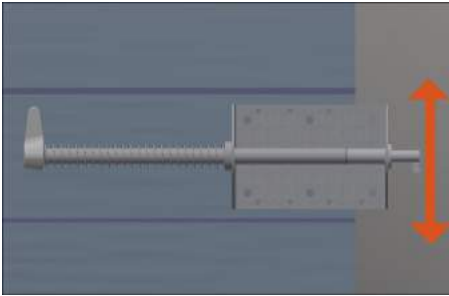

**Step 01:** First ensure the door is fully closed. Determine the position of the locking bolt to ensure that either parts do not clash with existing door fixings. Suggested height between 1.5m and 2m from floor level.

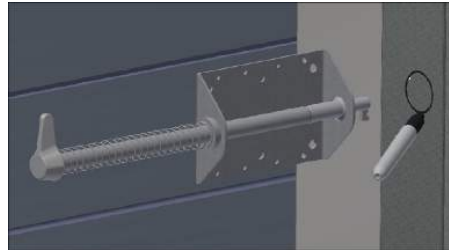

**Step 02:** Mark the position of the bolt clearance hole on the inside of the door running guide. Check that the lock and bolt do not clash with bay controls.



**Step 03:** Drill the clearance hole in the running guide using a 28mm tank cutter.



**Step 04:** Determine the position of the lock door, ensuring that the bolt entry hole aligns. Use the hole in the door running guide to align the lock.

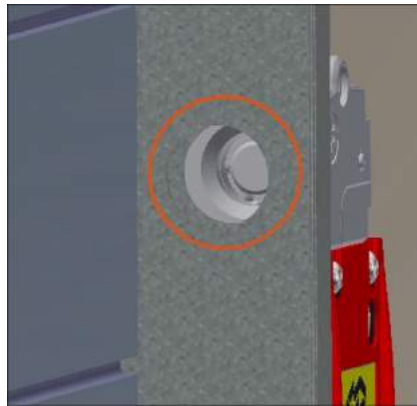

**Step 05:** Use the hole in the door running guide to align the lock.

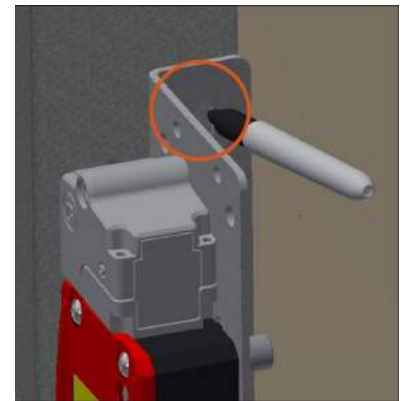

**Step 06:** Mark and drill the positions of the mounting bracket holes.



**Step 07:** Fix the lock and bracket in place with the screws provided.



**Step 08:** With the door fully closed, engage the bolt into the lock body, through the previously drilled hole in the door running guide. Mark the positions of the fixing holes in the door.



**Step 09:** Drill holes and fix in place using bolts, washers and nuts supplied. Trim excess bolt length if necessary.

### Specifications

Bolt Material	Stainless steel
Housing Material	Zink alloy to BS EN 12844
Finish	Red Polyester Powder Coat
Ingress Protection	IP67
Operating Force	0,5Nm
Retention Force - Locked	2500N
Max. Approach Speed	20M/min
Mechanical Life	>1,000,000 Switching Cycles
Max. Frequency of Operation	7,200/hour
Ambient Temperature	-5°C to 40°C (Mean over 24 hours = 35°C)
Max. Wire Cross Section to fit Connector	2,5mm <sup>2</sup>
Connector Type	Spring Activated Vibration Proof Block
Switch Conformance	DIN VDE 0660 Part 206 & IEC
Switching	Positive Break
Switching Control	3A
Switching Voltage	230V AC max
Isolating Distance	2x2mm per Switch Element
Contact Material	24VAC/VDC

### Maintenance Instructions

Under normal operating conditions very little maintenance is required. If used in dusty conditions, blowing out with compressed air will prevent a build up of sediment in the locks.

Under no circumstances, however, should the locks be oiled or greased as this causes the locks to clog and malfunction. All locking systems should be checked regularly for correct operation, security of fixings and condition of keys etc. The function of all keys that should be trapped must be checked under operating conditions, as should the ease of removal of released keys. In the event of malfunction, evident wear or damage, parts should be replaced or returned to Castell for repair if appropriate.

Users of interlock systems have a duty under Section 2 of the Health and Safety at Work etc Act 1974 to ensure that the systems are correctly installed and maintained in a satisfactory condition.

### Order Information

Please advise correct part number when ordering.

**(\*\* mandatory information)**

Part Number**	Description
006479/1	Hand 1
006479/2	Hand 2
007051	With Chain Kit

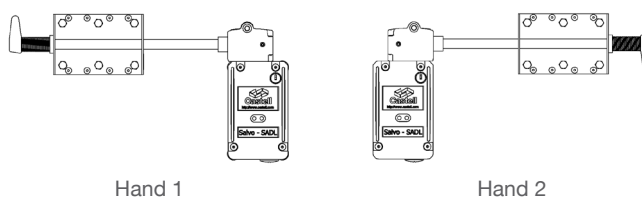



# **Section 4**

# **Loading Bay**

# **Barriers**



# Salvo Bollard

## User Guide



The Salvo Barrier comprises a pair of bollards, a chain kit and a choice of interlock (see table below). Each bollard is bolted to the warehouse floor, either side of the loading bay door.

### Operation

The Salvo Barrier can be fitted with either of the following interlocks: SADL-AIS, SMDL AI or SADL (See descriptions below).

The SMDL-AIS (Salvo Manual Door Lock) is a mechanical interlock used to positively bolt the barrier in the closed position. The switch contacts can be used for controlling power to the dock leveller or other ancillary electrical devices e.g. traffic lights. The unit incorporates a locking bolt with chain which connects to the barrier. Only when the key is inserted and turned, can the locking bolt be disengaged, allowing the barrier to be opened. The turning of the key closes the switch contacts.

The SMDL-AI (Salvo Manual Door Lock) is a mechanical interlock used to positively bolt the barrier in the closed position. The unit incorporates a locking bolt with chain to the barrier which connects to the barrier. Only when the key is inserted and turned, can the locking bolt be disengaged, allowing the barrier to be opened.

The SADL is a keyless solenoid controlled Lock that locks and unlocks dependent upon the signal received from the Salvo Control Panel (SCP). The unit incorporates a locking bolt with chain which connects to the barrier. Only when the signal is received from the SCP, can the locking bolt be disengaged, allowing the barrier to be opened.

### Precautions



To maintain high visibility, periodically clean the bollard.  
From time to time, check that all fixing screws remain tight.

### Maintenance

To maintain high visibility, periodically clean the bollard. From time to time, check that all fixing screws remain tight.

### Specifications

Post Material	Powder coated carbon steel
Cap Material	UV resistant ABS, black
Dimensions	1,016mm x 100mm x 150mm
Weight	16kg
Colour	Safety yellow
Mounting Hardware	Supplied

### Installation

#### Fixing Instructions

Installation begins with bolting the footplate to the floor of the warehouse.

- ① Mark the position of the fixing holes on the warehouse floor and drill with a suitable masonry drill.



- ② Bolt the footplate to the floor using the fixings provided.

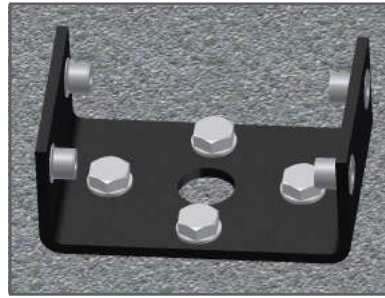

- ③ Lower the Bollard into place over the footplate.

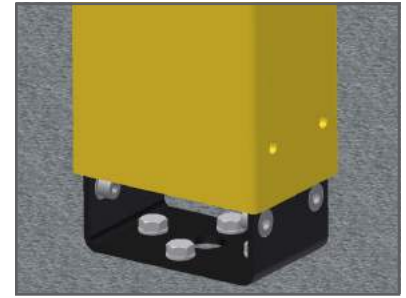

- ④ Secure the Bollard to the footplate with the bolts provided.

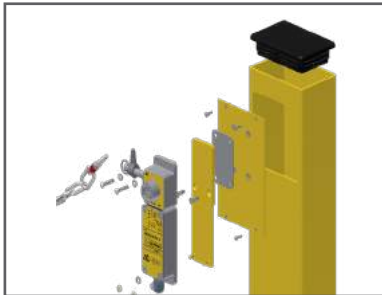

- ⑤ Fit appropriate kit to Bollards, test accordingly to complete installation.

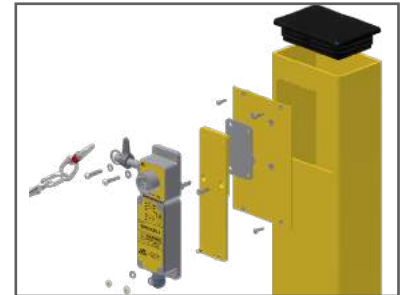
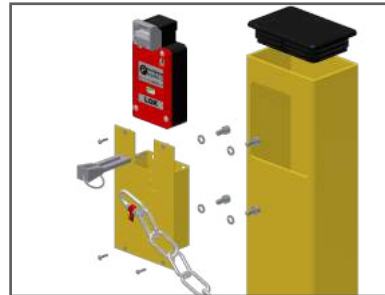

### Order Information

Please advise correct part number when ordering.  
(\*\* mandatory information)

Part Number**	Description/System Components
006513	SCB-SMDL-AIS-1 c/w Chain Kit & Bollard
006514	SCB-SMDL-AIS-2 c/w Chain Kit & Bollard
006515	SCB-SMDL-AI-1 c/w Chain Kit & Bollard
006516	SCB-SMDL-AI-2 c/w Chain Kit & Bollard
006517	SCB-SADL c/w Chain Kit & Bollard



# Section 5

# Peripherals

# Salvo Pedestal

## User Guide

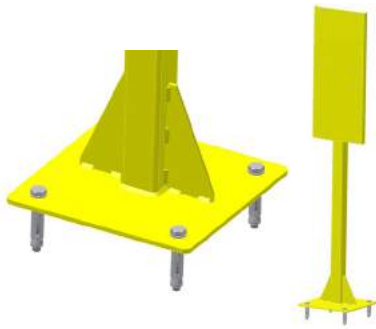

The Salvo Pedestal is bolted to the floor of the yard and is used primarily for installations that have a narrow bay pitch and limited wall access and fixing space. The pedestal is used in conjunction with Salvo Control Panel and Salvo Enclosure, double box.

### Specifications

Post Material	Powder Coated Carbon Steel
Height	1.46m
Weight	15kg
Colour	Safety Yellow
Mounting Hardware	4 x M10 Rawl Bolts (supplied).

### Precautions



To maintain high visibility, periodically clean the pedestal. From time to time, check that all fixing screws remain tight.

### Maintenance

### Installation

The location of the Pedestal is affected by the position of the existing bay canopy and/or curtains. Consideration must also be given to the accidental opening of the trailer doors during movement of the trailer. (Ensure that the trailer doors cannot strike the pedestal).

Additional steelwork (uni-strut) should be used to connect the pedestal to the bay wall, thereby providing greater stability. The SCP cable can be tied to the steel work for protection and support.

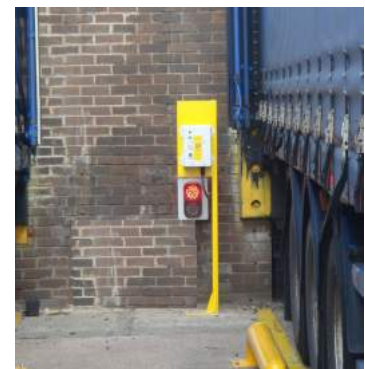

### Order Information

Please advise correct part number when ordering.  
**(\*\* mandatory information)**

**Part Number\*\***

006480

# Salvo Storage Enclosure

## User Guide



Salvo Storage Enclosures are used for the safe and dry storage of the Susie and/or Palm/Glad Hand locks. The enclosure can be mounted at a location most suitable to site operations. For example, on the warehouse exterior wall, adjacent to the loading bay door, or on a pedestal between each loading bay.

### Specifications

Material	ABS/FR (R59M) UL94 5VA Rated
Dimensions	232mm(W) x 302mm(H) x 172mm(D) (174mm with Mounting Plate)

### Precautions



To maintain high visibility, periodically clean the enclosure. From time to time, check that all fixing screws remain tight.

### Installation

Refer to mounting instructions illustrated on page 22-23.

# Salvo Storage Enclosure

## User Guide

### Order Information

Please advise correct part number when ordering.  
(\* mandatory information)

#### Part Number\*\*

Storage Enclosure	008002
-------------------	--------



Insert Plate for Susie only	008064
-----------------------------	--------



Insert Plate for SGL 008040 only	008065
----------------------------------	--------



Insert Plate for SGL 006504 & Susie	008066
-------------------------------------	--------



Door Assembly c/w T-bar handle	008067
--------------------------------	--------



# Salvo Presence detection and Alarming System

## User Guide



The Salvo Presence detection and Alarming System alerts users when a Salvo Susie or SGL is not placed back into the Salvo Storage Enclosure after use.

### Specifications

Material	Storage Box ABS/FR (R59M) UL94 5VA Rated Alarm box Glass fibre-reinforced polyester UL94 V-0 Rated
Dimensions	Storage Box 232mm(W) x 302mm(H) x 172mm(D) (174mm with Mounting Plate) Alarm Box 160mm(W) x 210mm(H) x 140mm(D)
Temperature	-20°C – 60°C
Weight	5,6 kg
Cable Entry size	M20 knockout
Ingress Protection	IP65 storage box IP65 alarm box
Power supply required	24VDC
Max power consumption	0,5 watt
Audio frequency	2 800Hz
Audio level	85-103 dB
Beacon color	Orange

### Precautions



To maintain high visibility, periodically clean the enclosure. From time to time, check that all fixing screws remain light.

### Order Information

Please advise correct part number when ordering.

**(\*\* mandatory information)**

Part Number**	Description/System Components
<b>S008003A</b>	for SGL-only holder version
<b>S008003B</b>	for Suzie & SGL holder version

## Installation

### Power Supply Input

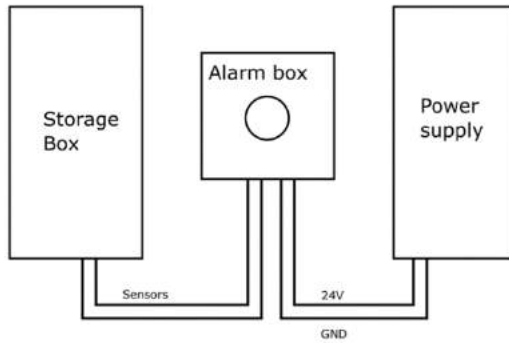

Connect 24VDC supply to alarm box. Power supply must include fuse. Fuse rating: 3Amp GSL003 Ø5 x 20mm Time-Lag Glass Tube Fuse (RS668-6007)



# Salvo Presence detection and Alarming System User Guide

## SPAS Wiring Diagram

### Step 1.

Open Alarm Box by unscrewing the top

### Step 2.

Connect T1 to Power supply 24VDC  
and connect T2 to Power Supply Ground.  
Connect 24V in SCP as per the drawing below

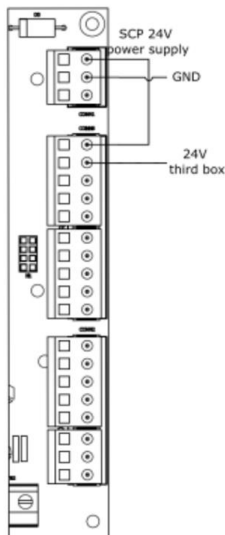

#### TERMINAL LAYOUT:

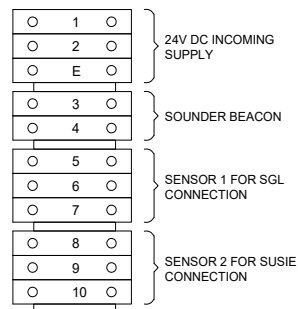

### Step 3.

Replace the top of the Alarm Box and secure using  
four screws.

# Salvo Presence detection and Alarming System User Guide

## SPAS Mounting Diagram

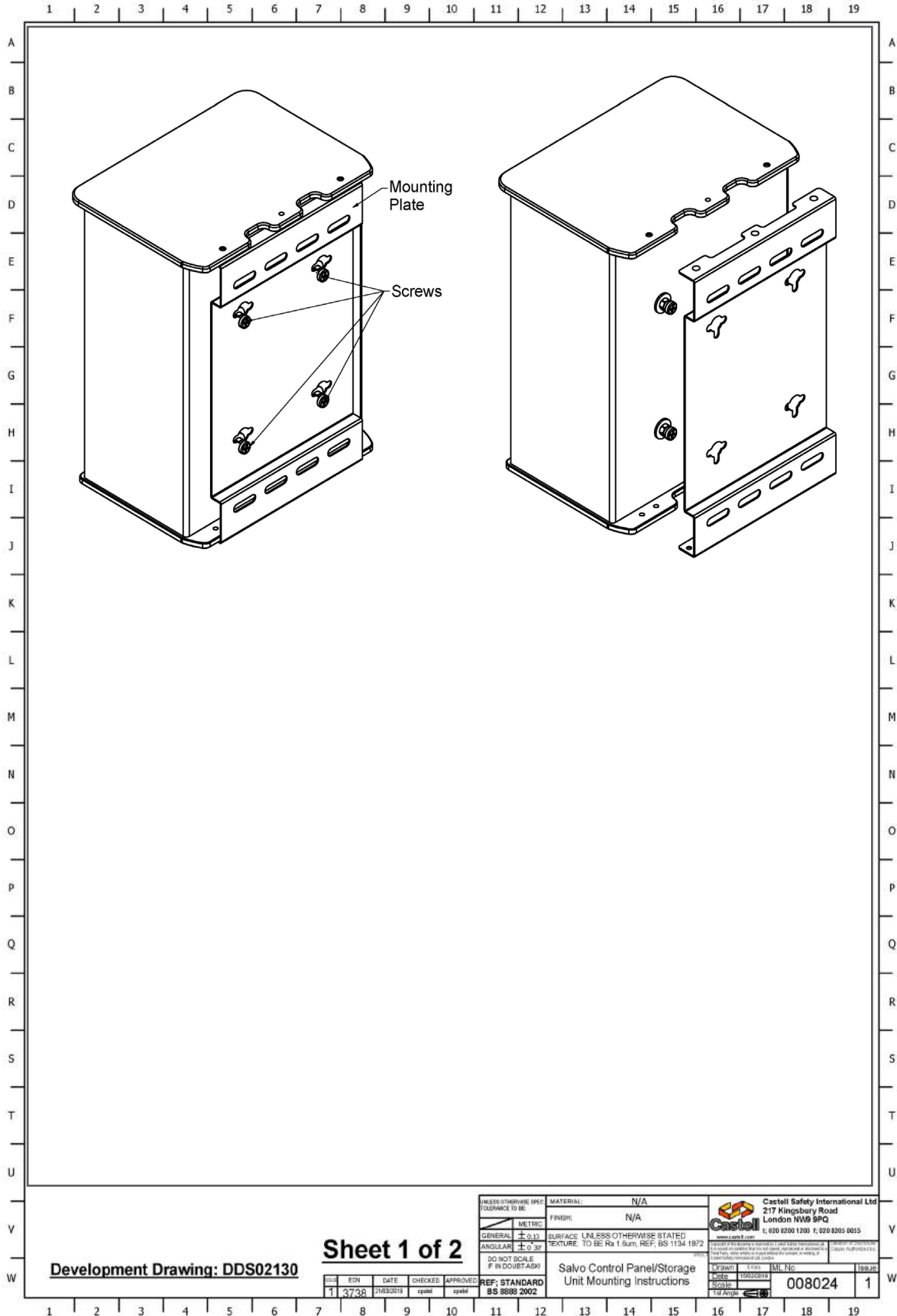

## SPAS Mounting Diagram

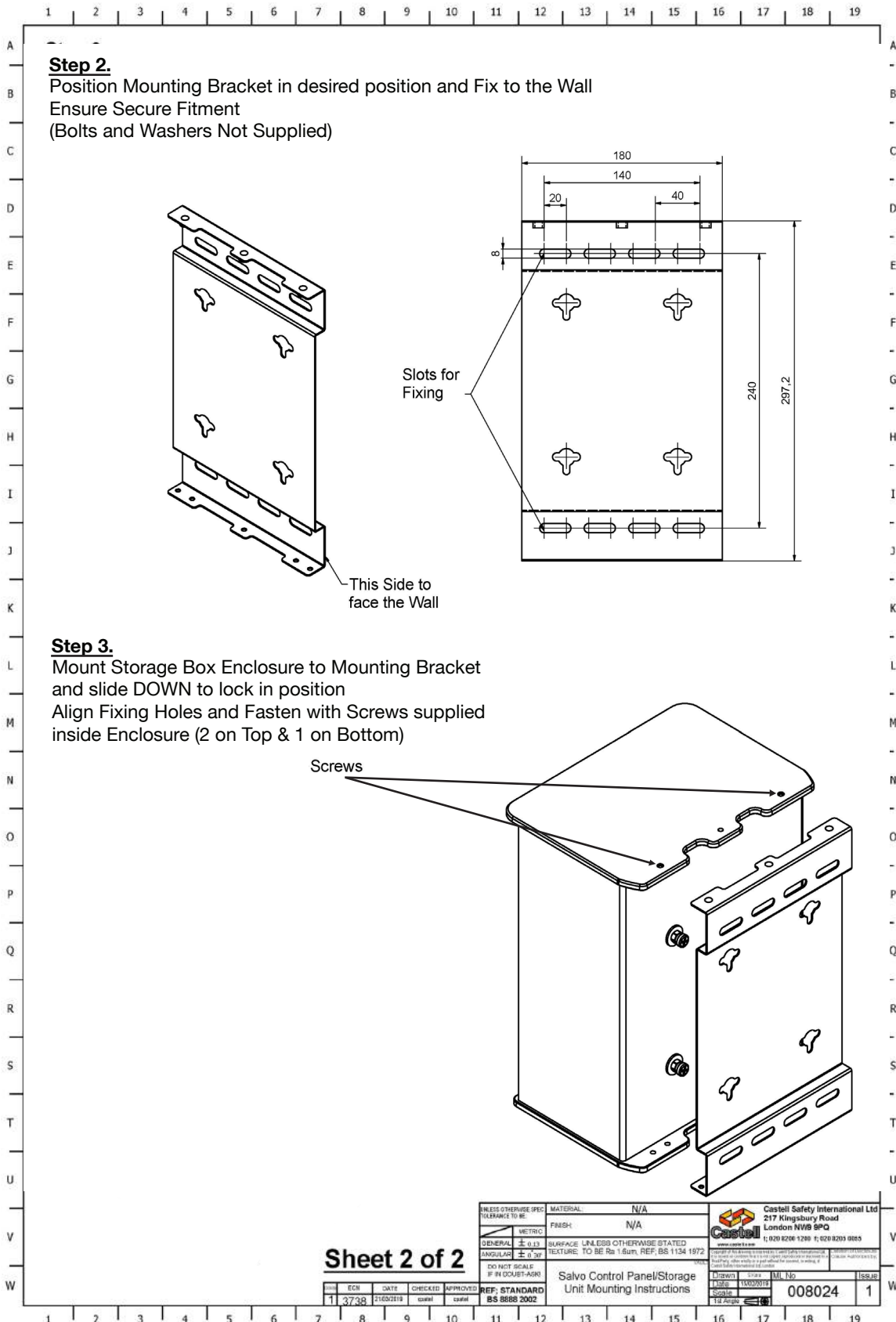

### Alarm Box Mounting

#### Wall mounting instructions

Open alarm box and mount the bottom directly to the wall with screws (not included)

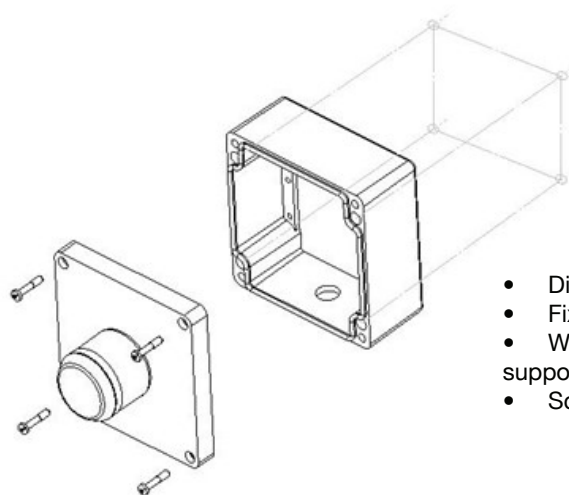

- Dimensions in millimeters
- Fixed by 4 screw, maximum diameter 6 millimeter (not included)
- When using dowels, select appropriate proper anchors for your support (not included)
- Screw Cover are included, torque of cover screws is 2,5 Nm

#### Wall mounting Holes dimension

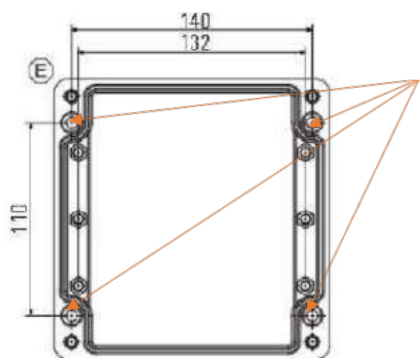

Screw Holes for wall mounting



D1 Ø	D2 Ø	Hole depth
10.5mm	6.6mm	20mm

# Salvo Traffic Light

## User Guide



Salvo Traffic Lights are a means of communicating the status of the loading bay door. The lights can be mounted inside, outside or on both sides of the loading bay. When mounted inside, a red light indicates that the bay door cannot be opened. A green light indicates that the door can be opened and loading or unloading commenced. When mounted outside, a red light indicates that the door is open the the vehicle must not drive away. A green light indicates that the door is closed and the vehicle can depart.

### Specifications

Dimensions	268mm(H) x 140mm(W) x 50mm(D)
Mounting	Surface
IP Rating (Front Assembly)	IP680 - IEC 60529, EN 60 529 (Components fully potted)
IP Rating (Rear Cavity)	IP400
Operational Temp. Range	-10°C - +50°C
Light Source	High Output LED
Light Output	40 x LED per circular array
Voltage	24VDC
Life Expectancy	+7 years
89/336/EEC [CENELEC - EN 50082-1]	EMC immunity: Light Industrial
89/336/EEC [CENELEC - EN 50081]	Emissions - Not applicable - EMC benign
73/23/EEC	Not applicable - Extra low voltage
2002/96/EC	Not applicable - Voluntary good practice

### Precautions



Installation should be carried out by a qualified electrician. Please retain this document.  
A separate control system is required.  
Do not wash with pressure jet.

### Wiring

Refer to SCP wiring schematic diagram on page 24.

### Order Information

Please advise correct part number when ordering.  
**(\*\* mandatory information)**

**Part Number\*\***

**006538**



# **Section 6**

# **Safety Critical Information**

The system must be designed to meet the requirements of the Health and Safety Executive and all current legislation. Attention is also drawn to the relevant codes of practice.

### 1. General Instructions

General guidance for the installation of all Castell products:-

- (a) Fixing of locks should be secure to prevent tampering or unauthorised removal. It is recommended that tamper-resistant screws and nuts are used or that they are sealed after tightening.
- (b) Fixing screws and brackets should be corrosion resistant and the appropriate tightening torques and anti-vibration washers should be used.
- (c) Locks and switches must be protected from the ingress of water and dust and products of suitable IP rating must be selected. Protective caps are available and locks can be selected with protective enclosures. The ingress of water and dust should be reduced by mounting the locks vertically, rather than 'face up', where possible.
- (d) Chemical corrosion of locks can be avoided with the various finishes for locks and keys that are available. Alternatively, most products are available in 100% stainless steel.
- (e) In general, the installation of Castell locks must not result in a torque in excess of 5.5 Nm (4 Lbs.ft) being transmitted through the lock centre via the key. This is a typical hand operating torque and additional leverage through the key, using tools of any kind, should be avoided.

### 2. Spare Keys, Master Keys, Spare Access Locks Actuation Bolts/Tongues

Castell will only supply spare keys and spare access lock bolts/ tongues when a signed order, with order number, is received on the customers headed paper. This is also required for figure lock master keys, in addition to which the customer is required to sign a document accepting responsibility for the use and storage of such keys. This is part of our ISO 9001 procedures and reflects our concern on this issue. Castell advise that extreme caution must be exercised when storing or using these products. Their use and security must be fully and adequately controlled using a permit to work system. Using spare/master keys or spare bolts/tongues will result in the defeat of the interlock system. Consequently this could lead to serious injury/fatality, damage to plant/machinery or damage to the product.

- Master keys are almost always unnecessary. Keys of the correct symbol should be used.
- Castell have an express order system for the rapid replacement of broken keys.

### 3. Verification

After installation it is essential to carry out a commissioning procedure to ensure that the interlock system performs the requirements for which it was designed. The procedures will vary considerably according to the application.

### 4. Training

Suitable training regarding the use and operation of the interlock system should be given to a all relevant people. Castell can offer training if required.

### 5. Safe Installation of Castell Electrical Products

Note: A SECURE EARTH CONNECTION TO ALL LOCKS IS MANDATORY.

It is a requirement of the IEE regulations and other standards, that the exposed and accessible metal parts of an electrical assembly are adequately earthed. This requirement is particularly critical in the case of key actuated locks since the key is conductive and is deliberately grasped by operators. Castell electrical products can be grouped into two categories, those that are self-contained for front-of-board mounting, and those that are supplied un-mounted for back-of-board installation by the customer. The products that are mounted in boxes or housings are Class 1 equipment are provided with earthing tags, which MUST be bonded, by the earthing conductor, to earth (TNS System).

The lock portions and metal structure of products for back-of-board mounting MUST either be:-

(a) Connected directly to earth via an earthing tag on the mounting screws, OR

(b) Bonded, with a sound electrical connection, onto a conductive structure, which in turn, is connected to earth, ensuring the correct earth fault loop impedance. Installation of electrical equipment must be carried out by a qualified electrician using I.E.E. recommended practice. In particular, the correct rating of products and the earthing of attached locks and metal structures, as described above, is imperative.



Installation should be carried out by a competent and qualified person who has read and understood these instructions. Any electrical installation must comply with standard “BS7671 – Requirements for Electrical Installations”, commonly referred to as the IEE Wiring Regulations, or any particular regulations and practices, specified by the local electricity supply company at the time of installation. Installation must be carried out by competent personnel qualified to current IEE or any equivalent regulations in force at the time of installation.

Castell offer an installation and maintenance service for its products and will be pleased to offer advice.

### 6. Maintenance of Castell Interlocks



**WARNING** – Disconnect Electrical Supply Before Opening Unit

Under normal operating conditions very little maintenance is required. If used in dusty conditions blowing out with compressed air will prevent a build up of sediment in the locks. The use of powdered graphite is recommended if necessary. Under no circumstances, however, should the locks be oiled or greased as this causes the locks to clog and malfunction. All locking systems should be checked regularly for correct operation, security of fixings and condition of keys etc. The entrapment of all keys that should be trapped must be checked under operating conditions, as should the ease of removal of liberated keys. In the event of malfunction, evident wear or damage, parts should be replaced or returned to Castell for repair if appropriate. Users of interlock systems have a duty under section 2 of the Health and Safety at Work Act 1974 to ensure that the systems are not only correctly installed but are maintained in a satisfactory condition.

We are here to help. Castell offer an installation and maintenance service as well as advice on the selection of products.

### 7. Guidance

The Health and Safety at Work Act 1974  
The Management of Health and Safety at Work Regulations 1999  
HSE guidance HSG136  
FTA loading dock safety guidance





Castell Safety International  
The Castell Building  
217 Kingsbury Road  
London, NW9 9PQ  
UK

t: +44 (0)20 8200 1200  
f: +44 (0)20 8205 0055

[sales@castell.com](mailto:sales@castell.com)  
[www.castell.com](http://www.castell.com)

